



SHAPING TOMORROW

# PRODUCT CATALOGUE



# Together We Develop A Better Future

PT Gunung Raja Paksi Tbk

## Table of contents

---

3	<b>Who we are</b>
5	<b>Production Workflow</b>

---

9	<b>Flat Products</b>
11	Steel Plate
23	Hot Rolled Coil (HRC)
29	Coil Plate

---

34	<b>Downstream Products</b>
35	Cold Roll Coil (CRC)
37	Cut to Shape
39	ERW Pipe
49	Expanded Mesh
51	Lipped Channel (CNP)
53	Spiral Pipe
55	Square & Rectangular Pipe
57	Welded Beam

---

61	<b>Service Center</b>
65	<b>Steel Application</b>
69	<b>Certification</b>

---

# Who We Are

**A to Z Under One Roof, our company was established in 1970 under the name PT Gunung Raja Paksi Tbk (GRP)**

GRP has proven its capabilities by expanding into a wider range of steel products and this has GRP, as one of leading steel producers in Indonesia.

The Commissioning of our first Hot Rolled Steel Machine was in the last quarter of the year 2000. GRP always emphasize foremost on professional performances through the in-Depth experience & accompanied by comprehensive approach in our efforts to provide the best services and the best possible value-added products. This ensures that we are able to meet the needs of our customer no matter how complicate it may be. Among the products range consist of Flat, Coils, Welded Pipe, and Decking Products.

GRP has ability to process the basic materials further and expands its products line into a variety of light fabricated products to suit specific requirement.

**The services we provide are:**

Forming Services Center  
Plate Services Center  
Coil Services Center



# Production Workflow

# Production Workflow

## Integrated Workflow of PT Gunung Raja Paksi Tbk

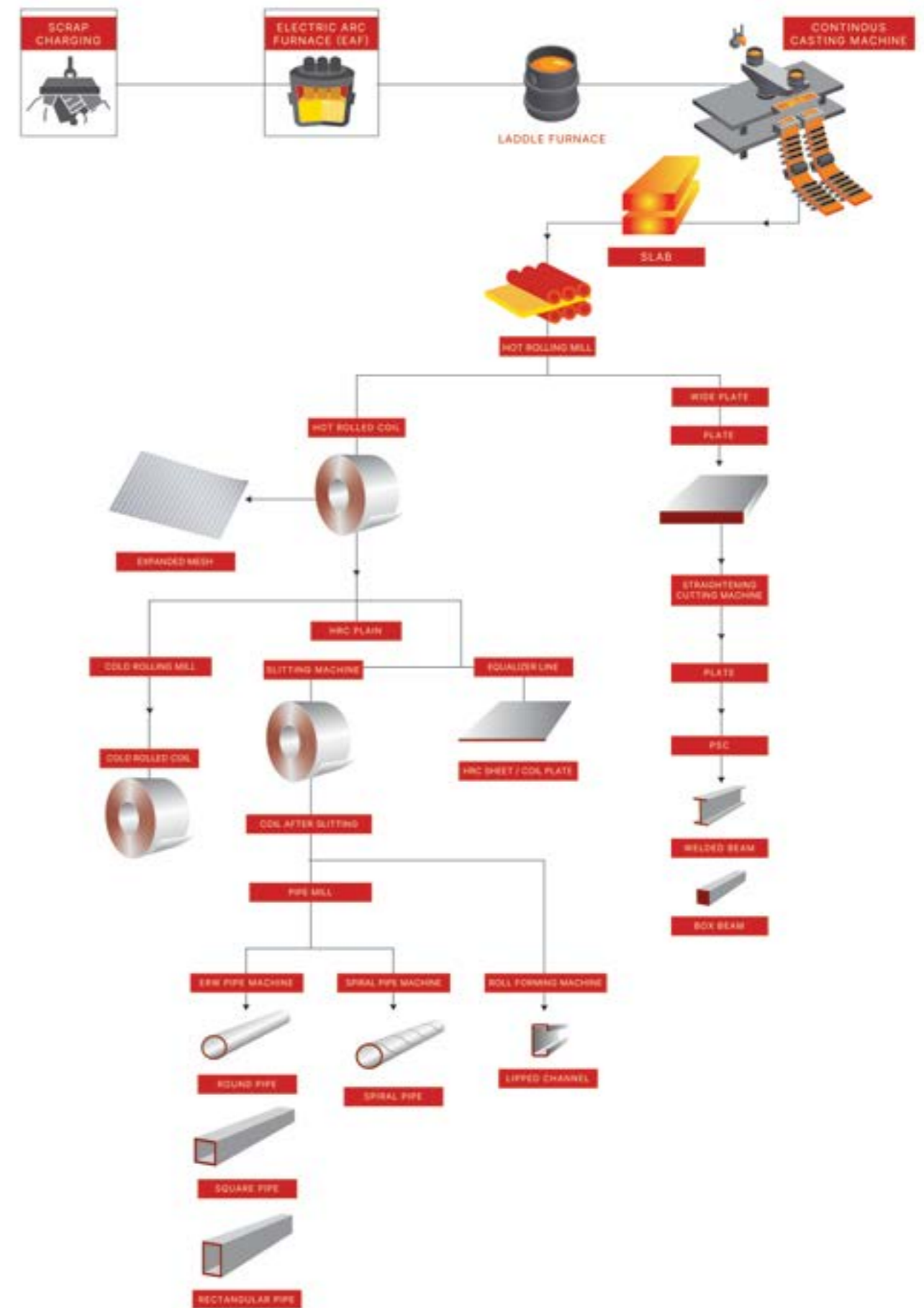



GeGa

Various end products covering all types of Hot and Cold Plates, Hot and Cold Rolled Coils, as well as various types of downstream plates and other coils.

**Steel Plate**

**Hot Rolled Coil (HRC)**

**Coil Plate**

# Flat Products



## Steel Plate

PT Gunung Raja Paksi (GRP) understands the diverse demand for this form of flat steel as we produce steel plates from Mild Steel, High-Strength Low Alloy, pressure Vessel, Ship Building Plates, and for general purpose uses.

We also understand the various uses and applications of steel plates, and as one of the leading steel mill, we can produce the majority of plate grades and standards as issued by the world's major third party certification entities such as ABS, BKI, DNV, LR, GL, TUV, NK & CE Marked and each with their different sub grades.

To further enhance the performance of our steel product, we have a heat treatment facility for normalizing. This process is to accommodate with a minimum thickness of 6 mm steel plate and will provide the additional performance enhancement to our high tensile plate range. Combining our broad experience in steel industry and extensive range of cutting machines, we are able to fulfill various dimensions and grades required by our customers.



**Annual Capacity: 480,000 MT/year**  
**Thickness: 6 - 150 mm, Width: 1200 - 3050 mm Max**  
**Grade: ASTM, JIS, EN, DIN, AS/NZS, BS, API 5L PSL 1; PSL 2, API 2H, API 2W, BKI, ABS, LR**

World class steel plates are manufactured at Gunung Raja Paksi Plate Mill with state-of-the art of technology to ensure their quality. These plates come in various standards, grades, and sizes to meet your requirement for direct use, rolling, or fabricating. Ranging from mild steel to high strength steel, our products are subjected to stringent quality control protocols.



Application	Standard & Specification	Grade
General Structural and Weldable Structural Steel	ASTM	A36, A283, A131, A529, A572, A573, A633, A709,
	JIS	SS400, SS490, SS540, SM400, SM490, SM520, SM570
	EN	S235JR/J0/J2, S275JR/J0/J2/N/ML, S355JR/J0/J2/N/ML, S420M/ML, S460M/ML
	DIN	ST 37.2, ST 44.2, ST 52.3
	AS/NZS	200, 250, 300, 350, 400, 450
Pressure Vessel Steel	BS	40, 43, 50, 55
	ASTM	A285, A516
Line pipe Steel	EN	P235GH, P265GH, P275NH/NL1, P295GH, P355GH/NH/NL1/M/ML1
	API 5L PSL 1; PSL 2	A, B, X42, X46, X52, X56, X60, X65, X70
Offshore Structural Steel	API 2H	42, 50
	API 2W	50, 60
Weather Resistant Steel	ASTM	A588
	JIS	SMA 400, SMA 490,
	EN	S235 J0W/J2W, S355 J0W/J2W/K2W
	AS/NZS	WR 250
High Carbon Steel	ASTM	1042 - 1050
	JIS	S 45 - S 50
	AS/NZS	K1042
Ship Building Quality	EN	C 45
	BKI, ABS, LR, DNVGL, BV, NK	A, B, D, E, AH/DH/EH 32/36/40
Gas Cylinders Steel	JIS	SG 255, SG 295
Forming and Drawing Steel	ASTM	A1006, A1008, A1011CS/DS,
	JIS	SAPH 400/440, SPHC, SPHD, SPHT-1/2/3

### Calculated Plate Weight (From Thickness & Size)

Width x Length (in mm)	1219 x 2438	1219 x 6096	1524 x 3048	1524 x 6096	1524 x 9144	1524 x 12192	1829 x 6096	1829 x 12192	2133 x 6096	2133 x 12192	2438 x 6096	2438 x 12192	2743 x 6096	2743 x 12192	3048 x 6096	3048 x 12192
Width x Length (in ft)	4' x 8'	4' x 20'	5' x 10'	5' x 20'	5' x 30'	5' x 40'	6' x 20'	6' x 40'	7' x 20'	7' x 40'	8' x 20'	8' x 40'	9' x 20'	9' x 40'	10' x 20'	10' x 40'
Width x Length (in inch)	48 x 96	48 x 240	60 x 120	60 x 240	60 x 360	60 x 480	72 x 240	72 x 480	84 x 240	84 x 480	96 x 240	96 x 480	108 x 240	108 x 480	120 x 240	120 x 480
Thickness (mm)																
8	187	467	292	583	875	1.167	700	1.400	817	1.633	933	1.867	1.050	2.100	1.167	2.334
9	210	525	328	656	985	1.313	788	1.575	919	1.837	1.050	2.100	1.181	2.363	1.313	2.625
10	233	583	365	729	1.094	1.459	875	1.750	1.021	2.041	1.167	2.333	1.313	2.625	1.459	2.917
12	280	700	438	875	1.313	1.750	1.050	2.101	1.225	2.450	1.400	2.800	1.575	3.150	1.750	3.501
12.7	296	741	463	926	1.389	1.852	1.112	2.223	1.296	2.593	1.482	2.963	1.667	3.334	1.852	3.705
14	327	817	511	1.021	1.532	2.042	1.225	2.451	1.429	2.858	1.633	3.267	1.838	3.675	2.042	4.084
15	350	875	547	1.094	1.641	2.188	1.313	2.626	1.531	3.062	1.750	3.500	1.969	3.938	2.188	4.376
16	373	933	583	1.167	1.750	2.334	1.400	2.801	1.633	3.266	1.867	3.733	2.100	4.200	2.334	4.667
18	420	1.050	656	1.313	1.969	2.625	1.575	3.151	1.837	3.675	2.100	4.200	2.363	4.725	2.625	5.251
19	443	1.108	693	1.386	2.078	2.771	1.663	3.326	1.939	3.879	2.217	4.433	2.494	4.988	2.771	5.543
20	467	1.167	729	1.459	2.188	2.917	1.750	3.501	2.041	4.083	2.333	4.667	2.625	5.250	2.917	5.834
22	513	1.283	802	1.604	2.407	3.209	1.926	3.851	2.246	4.491	2.567	5.133	2.888	5.776	3.209	6.418
24	560	1.400	875	1.750	2.625	3.501	2.101	4.201	2.450	4.899	2.800	5.600	3.150	6.301	3.501	7.001
25	583	1.458	912	1.823	2.735	3.646	2.188	4.376	2.552	5.104	2.917	5.833	3.282	6.563	3.646	7.293
25.4	593	1.482	926	1.852	2.779	3.705	2.223	4.446	2.593	5.185	2.963	5.927	3.334	6.668	3.705	7.410
26	607	1.517	948	1.896	2.844	3.792	2.276	4.551	2.654	5.308	3.033	6.067	3.413	6.826	3.792	7.585
28	653	1.633	1.021	2.042	3.063	4.084	2.451	4.901	2.858	5.716	3.267	6.533	3.675	7.351	4.084	8.168
30	700	1.750	1.094	2.188	3.282	4.376	2.626	4.251	3.062	6.124	3.500	7.000	3.938	7.876	4.376	8.751
32	747	1.867	1.167	2.334	3.501	4.667	2.801	5.602	3.266	6.533	3.733	7.467	4.200	8.401	4.667	9.335
36	840	2.100	1.313	2.625	3.938	5.251	3.151	6.302	3.675	7.349	4.200	8.400	4.725	9.451	5.251	10.502
38	887	2.217	1.386	2.771	4.157	5.543	3.326	6.652	3.879	7.757	4.433	8.867	4.988	4.976	5.543	11.085
40	933	2.333	1.459	2.917	4.376	5.834	3.501	7.002	4.083	8.166	4.667	9.333	5.250	10.501	5.834	11.669
45	1.050	2.625	1.641	3.282	4.923	6.564	3.939	7.877	4.593	9.186	5.250	10.500	5.907	11.814	6.564	13.127
50	1.166	2.917	1.823	3.646	5.470	7.293	4.376	8.752	5.104	10.207	5.833	11.667	6.563	13.126	7.293	14.586
55	1.283	3.208	2.006	4.011	6.017	8.022	4.814	9.628	5.614	11.228	6.417	12.833	7.219	14.439	8.022	16.044
60	1.400	3.500	2.188	4.376	6.564	8.751	5.251	10.503	6.124	12.249	7.000	14.000	7.876	15.751	8.751	17.503
65	1.516	3.792	2.370	4.740	7.111	9.481	5.689	11.378	6.635	13.269	7.583	15.167	8.532	17.064	9.481	18.962
70	1.633	4.083	2.553	5.105	7.658	10.210	6.127	12.253	7.145	14.290	8.167	16.333	9.188	18.377	10.210	20.420
75	1.750	4.375	2.735	5.470	8.204	10.939	6.564	13.129	7.655	15.311	8.750	17.500	9.845	19.689	10.939	21.879
80	1.866	4.667	2.917	5.834	8.751	11.669	7.002	14.004	8.166	16.331	9.333	18.667	10.501	21.002	11.669	23.337
85	1.983	4.958	3.099	6.199	9.298	12.398	7.440	14.879	8.676	17.352	9.917	19.833	11.157	22.315	12.398	24.796
90	2.100	5.250	3.282	6.564	9.845	13.127	7.877	15.754	9.186	18.373	10.500	21.500	11.814	23.627	13.127	26.254
95	2.216	5.542	3.464	6.928	10.392	13.856	8.315	16.630	9.697	19.394	11.083	22.167	12.470	24.940	13.856	27.713
100	2.333	5.833	3.646	7.293	10.939	14.586	8.752	17.505	10.207	20.414	11.667	23.333	13.126	26.252	14.586	29.172

Calculated considering specific gravity of steel as 7.85 Kg/mm2, and dimension in mm. Not Available Size

General & Weldable Structural Steel - Mild Steel

SPECIFICATION	GRADE	Prod. Thick (mm)	Thick. Range (mm)	MECHANICAL PROPERTIES													GENERAL PURPOSE			
				TENSILE TEST							IMPACT TEST									
				YS (N/mm <sup>2</sup> )			TS (N/mm <sup>2</sup> )			EL (%)	+20		0		-20			-40		
				Min	Max	200	80	50	5.65V <sub>50</sub>	AVG	AVG	AVG	AVG	AVG	AVG	AVG		AVG		
ASTM A-36 / ASME A-36		2-150	≤20	250 <sup>a</sup>	400	550	20 <sup>b</sup>	-	23 <sup>b</sup>	-	-	-	-	-	-	-	-	-	SPECIFICATION FOR CARBON STRUCTURAL STEEL	
			>20 ≤40	250 <sup>a</sup>	400	550	20 <sup>b</sup>	-	23 <sup>b</sup>	-	-	-	-	-	-	-	-	-		
			>40 ≤65	250 <sup>a</sup>	400	550	20 <sup>b</sup>	-	23 <sup>b</sup>	-	-	-	-	-	-	-	-	-		-
			>65 ≤100	250 <sup>a</sup>	400	550	20 <sup>b</sup>	-	23 <sup>b</sup>	-	-	-	-	-	-	-	-	-		-
ASTM A-283 / ASME A-283	A	2-100	≤40	165	310	415	27 <sup>c</sup>	-	30 <sup>c</sup>	-	-	-	-	-	-	-	-	-	LOW AND INTERMEDIATE TENSILE STRENGTH CARBON STEEL PLATES	
			>40	165	310	415	27 <sup>c</sup>	-	30 <sup>c</sup>	-	-	-	-	-	-	-	-	-		
			≤40	185	345	450	25 <sup>d</sup>	-	28 <sup>d</sup>	-	-	-	-	-	-	-	-	-		-
			>40	185	345	450	25 <sup>d</sup>	-	28 <sup>d</sup>	-	-	-	-	-	-	-	-	-		-
ASTM A-131	A	5-80	≤25	235	400	520	21	-	24	-	-	-	-	-	-	-	-	-	Structural Steel for Ships	
			>25 ≤35	235	400	520	21	-	24	-	-	-	-	-	-	-	-	-		
			>35 ≤50	235	400	520	21	-	24	-	-	-	-	-	-	-	-	-		
			>50 ≤70	235	400	520	21	-	24	-	34	-	-	-	-	-	-	-		
ASTM A-573 / ASME SA-573	58	6-40	≤13	220	400	490	21 <sup>e</sup>	-	24 <sup>e</sup>	-	-	-	-	-	-	-	-	-	STRUCTURAL CARBON STEEL PLATES WITH IMPROVED TOUGHNESS	
			>13 ≤40	220	400	490	21 <sup>e</sup>	-	24 <sup>e</sup>	-	-	-	-	-	-	-	-	-		
			≤20	250 <sup>a</sup>	400	550	20 <sup>b</sup>	-	23 <sup>b</sup>	-	-	-	-	-	-	-	-	-		
			>20 ≤40	250 <sup>a</sup>	400	550	20 <sup>b</sup>	-	23 <sup>b</sup>	-	-	-	-	-	-	-	-	-		
ASTM A-709 / ASME SA 709	36	2-150	>40 ≤65	250 <sup>a</sup>	400	550	20 <sup>b</sup>	-	23 <sup>b</sup>	-	-	-	-	-	-	-	-	-	STRUCTURAL STEELS FOR BRIDGES	
			>65 ≤100	250 <sup>a</sup>	400	550	20 <sup>b</sup>	-	23 <sup>b</sup>	-	-	-	-	-	-	-	-	-		
			>100	250 <sup>a</sup>	400	550	20 <sup>b</sup>	-	23 <sup>b</sup>	-	-	-	-	-	-	-	-	-		
			≤5	245.00	400	510	-	-	21	-	-	-	-	-	-	-	-	-		
JIS G 3101	SS-400	2-150	>5 ≤16	245	400	510	17	-	-	-	-	-	-	-	-	-	-	-	HOT ROLLED STEEL FOR GENERAL STRUCTURE	
			>16 ≤40	235	400	510	21	-	-	-	-	-	-	-	-	-	-	-		
			>40 ≤100	215 <sup>a</sup>	400	510	-	-	23 <sup>b</sup>	-	-	-	-	-	-	-	-	-		
			>100	205	400	510	-	-	23 <sup>b</sup>	-	-	-	-	-	-	-	-	-		
SM 400 A	2-150	>5 ≤16	245.00	400	510	18	-	-	-	-	-	-	-	-	-	-	-	HOT ROLLED STEEL FOR WELDED STRUCTURE		
		>16 ≤40	235.00	400	510	22	-	-	-	-	-	-	-	-	-	-	-			
		>40 ≤75	215.00	400	510	-	-	24	-	-	-	-	-	-	-	-	-			
		>75 ≤100	215.00	400	510	-	-	24	-	-	-	-	-	-	-	-	-			
SM 400 B	2-150	>5 ≤16	245	400	510	18	-	-	-	27 <sup>f</sup>	-	-	-	-	-	-	-	HOT ROLLED STEEL FOR WELDED STRUCTURE		
		>16 ≤40	235	400	510	22	-	-	-	27	-	-	-	-	-	-	-			
		>40 ≤75	215	400	510	-	-	24	-	-	-	-	-	-	-	-	-			
		>75 ≤100	215	400	510	-	-	24	-	-	-	-	-	-	-	-	-			
SM 400 C	2-150	>5 ≤16	245	400	510	18	-	-	-	47 <sup>g</sup>	-	-	-	-	-	-	-	HOT ROLLED STEEL FOR WELDED STRUCTURE		
		>16 ≤40	235	400	510	22	-	-	-	47	-	-	-	-	-	-	-			
		>40 ≤75	215	400	510	-	-	24	-	-	-	-	-	-	-	-	-			
		>75 ≤100	215	400	510	-	-	24	-	-	-	-	-	-	-	-	-			
S 235 JR + AR	2-150	<3	235	360	510	-	-	19	-	-	27	-	-	-	-	-	-	STRUCTURAL STEEL		
		≥3 ≤16	235	360	510	-	-	24	-	27	-	-	-	-	-	-	-			
		>16 ≤40	225	360	510	-	-	24	-	27	-	-	-	-	-	-	-			
		>40 ≤63	215	360	510	-	-	23	-	27	-	-	-	-	-	-	-			
EN 10025-2:2004	S 235 JO + AR	2-150	>63 ≤80	215	360	510	-	-	22	-	27	-	-	-	-	-	-	STRUCTURAL STEEL		
			>80 ≤100	215	360	510	-	-	22	-	27	-	-	-	-	-	-			
			>100 ≤150	195	350	500	-	-	22	-	27	-	-	-	-	-	-			
			>150 ≤200	185	340	490	-	-	21	-	27	-	-	-	-	-	-			
S 235 J2 + N	2-150	<3	235	360	510	-	-	19	-	-	27	-	-	-	-	-	-	STRUCTURAL STEEL		
		≥3 ≤16	235	360	510	-	-	24	-	27	-	-	-	-	-	-				
		>16 ≤40	225	360	510	-	-	24	-	27	-	-	-	-	-	-				
		>40 ≤63	215	360	510	-	-	23	-	27	-	-	-	-	-	-				

<sup>a</sup>Nilai ini sama dengan 27 Joule pada -30°C

General & Weldable Structural Steel - Mild Steel

SPECIFICATION	GRADE	Prod. Thick (mm)	Thick. Range (mm)	MECHANICAL PROPERTIES													GENERAL PURPOSE		
				TENSILE TEST							IMPACT TEST								
				YS (N/mm <sup>2</sup> )			TS (N/mm <sup>2</sup> )			EL (%)	+20		0		-20			-40	
				Min	Max	200	80	50	5.65V <sub>50</sub>	AVG	AVG	AVG	AVG	AVG	AVG	AVG		AVG	
S 275 N	6-100	<3	275	370	510	-	-	24	-	55	47	40	-	31	27	20	-	WELDABLE FINE GRAIN STRUCTURAL STEEL	
		≥3 ≤16	275	370	510	-	-	24	-	55	47	40	-	31	27	20	-		
		>16 ≤40	265	370	510	-	-	24	-	55	47	40	-	31	27	20	-		
		>40 ≤63	255	370	510	-	-	24	-	55	47	40	-	31	27	20	-		
EN 10025-3:2004	S 275 NL	6-100	<3	275	370	510	-	-	24	63	55	47	31	40	34	27	20	WELDABLE FINE GRAIN STRUCTURAL STEEL	
			≥3 ≤16	275	370	510	-	-	24	63	55	47	31	40	34	27	20		
			>16 ≤40	265	370	510	-	-	24	63	55	47	31	40	34	27	20		
			>40 ≤63	255	370	510	-	-	24	63	55	47	31	40	34	27	20		
DIN 17100 (1980)	ST 37.2	6-80	≤16	235	340	470	24	-	-	-	27	-	-	-	-	-	-	STEEL FOR GENERAL STRUCTURAL PURPOSE	
			>16 ≤25	225	340	470	24	-	-	-	-	-	-	-	-	-	-		
			>25 ≤40	225	340	470	24	-	-	-	-	-	-	-	-	-	-		
			>40 ≤63	215	340	470	23	-	-	-	-	-	-	-	-	-	-		
AS/NZS 3678 ACRS Certificate No. 171202	250	5-100	≥25 ≤8	200	300	-	-	-	-	24 <sup>a</sup>	-	-	-	-	-	-	-	STRUCTURAL STEEL HOT ROLLED PLATES, FLOORPLATES AND SLABS	
			>8 ≤12	200	300	-	-	-	-	24 <sup>a</sup>	-	-	-	-	-	-	-		
			>12 ≤20	300	-	-	-	-	-	24 <sup>a</sup>	-	-	-	-	-	-	-		
			>20 ≤32	300	-	-	-	-	-	24 <sup>a</sup>	-	-	-	-	-	-	-		
BS 4360	40 A	5-80	≤16	235	340	500	22 <sup>a</sup>	-	25 <sup>b</sup>	-	25	-	-	-	-	-	-	WELDABLE STRUCTURAL STEELS	
			>16 ≤40	225	340	500	22	25	-	25	-	25	-	-	-	-	-		
			>40 ≤63	215	340	500	22	25	-	25	-	25	-	27	-	-	-		
			>63 ≤100	205	340	500	22	25	-	25	-	25	-	27	-	-	-		
BS 4360	40 B	5-80	≤16	235	340	500	22 <sup>a</sup>	-	25 <sup>b</sup>	-	25	-	27	-	-	-	-	WELDABLE STRUCTURAL STEELS	
			>16 ≤40	225	340	500	22	25	-	25	-	25	-	27	-	-	-		
			>40 ≤63	215	340	500	22	25	-	25	-	25	-	27	-	-	-		
			>63 ≤100	205	340	500	22	25	-	25	-	25	-	27	-	-	-		
BS 4360	40 C	5-80	≤16	235	340	500	22 <sup>a</sup>	-	25 <sup>b</sup>	-	25	-	27	-	-	-	-	WELDABLE STRUCTURAL STEELS	
			>16 ≤40	225	340	500	22	25	-	25	-	25	-	27	-	-	-		
			>40 ≤63	215	340	500	22	25	-	25	-	25	-	27	-	-	-		
			>63 ≤100	210	340	500	22	25	-	25	-	25	-	27	-	-	-		
BS 4360	40 D	8-80	≤16	235	340	500	22 <sup>a</sup>	-	25 <sup>b</sup>	-	25	-	27	-	-	-	-	WELDABLE STRUCTURAL STEELS	
			>16 ≤40	225	340	500	22	25	-	25	-	25	-	27	-	-	-		
			>40 ≤63	215	340	500	22	25	-	25	-	25	-	27	-	-	-		
			>63 ≤100	215	340	500	22	25	-	25	-	25	-	27	-	-	-		
BS 4360	43 A	5-80	≤16	275	430	580													

General & Weldable Structural Steel - High Strength Steel (Yield Strength ± 320 - 400 Mpa)

SPECIFICATION	GRADE	Prod. Thick (mm)	Thick. Range (mm)	MECHANICAL PROPERTIES																GENERAL PURPOSE		
				TENSILE TEST								IMPACT TEST										
				YS (N/mm <sup>2</sup> )			TS (N/mm <sup>2</sup> )			TR		EL (%)		+20		0		-20			-40	
				Min	Max	200	80	50	5.65V <sub>50</sub>	AVG	AVG	AVG	AVG	AVG	AVG	AVG	AVG	AVG	AVG		AVG	
ASTM A 131	AH32	6-80	>6.4 ≤ 12.5	315	440	590	19	-	22	-	-	31	-	-	-	22	-	-				
			>12.5 ≤ 20	315	440	590	19	-	22	-	-	31	-	-	-	22	-	-				
			>20 ≤ 25	315	440	590	19	-	22	-	-	31	-	-	-	22	-	-				
			>25 ≤ 35	315	440	590	19	-	22	-	-	31	-	-	-	22	-	-				
			>35 ≤ 50	315	440	590	19	-	22	-	-	31	-	-	-	22	-	-				
			>50 ≤ 70	315	440	590	19	-	22	-	-	28	-	-	-	26	-	-				
	>70 ≤ 100	315	440	590	19	-	22	-	-	46	-	-	-	31	-	-						
	DH32	6-80	>6.4 ≤ 12.5	315	440	590	19	-	22	-	-	31	-	-	-	22	-	-				
			>12.5 ≤ 20	315	440	590	19	-	22	-	-	31	-	-	-	22	-	-				
			>20 ≤ 25	315	440	590	19	-	22	-	-	31	-	-	-	22	-	-				
			>25 ≤ 35	315	440	590	19	-	22	-	-	31	-	-	-	22	-	-				
			>35 ≤ 50	315	440	590	19	-	22	-	-	31	-	-	-	22	-	-				
			>50 ≤ 70	315	440	590	19	-	22	-	-	28	-	-	-	26	-	-				
	>70 ≤ 100	315	440	590	19	-	22	-	-	46	-	-	-	31	-	-						
	EH32	8-60	>6.4 ≤ 12.5	315	440	590	19	-	22	-	-	31	-	-	-	22	-	-				
			>12.5 ≤ 20	315	440	590	19	-	22	-	-	31	-	-	-	22	-	-				
			>20 ≤ 25	315	440	590	19	-	22	-	-	31	-	-	-	22	-	-				
			>25 ≤ 35	315	440	590	19	-	22	-	-	31	-	-	-	22	-	-				
			>35 ≤ 50	315	440	590	19	-	22	-	-	31	-	-	-	22	-	-				
			>50 ≤ 70	315	440	590	19	-	22	-	-	28	-	-	-	26	-	-				
	>70 ≤ 100	315	440	590	19	-	22	-	-	46	-	-	-	31	-	-						
	ASTM A 529	AH36	6-80	>6.4 ≤ 12.5	355	490	620	19	-	22	-	-	34	-	-	24	-	-				
				>12.5 ≤ 20	355	490	620	19	-	22	-	-	34	-	-	24	-	-				
				>20 ≤ 25	355	490	620	19	-	22	-	-	34	-	-	24	-	-				
>25 ≤ 35				355	490	620	19	-	22	-	-	34	-	-	24	-	-					
>35 ≤ 50				355	490	620	19	-	22	-	-	34	-	-	24	-	-					
>50 ≤ 70				355	490	620	19	-	22	-	-	41	-	-	27	-	-					
>70 ≤ 100		355	490	620	19	-	22	-	-	50	-	-	34	-	-							
DH36		6-80	>6.4 ≤ 12.5	355	490	620	19	-	22	-	-	34	-	-	24	-	-					
			>12.5 ≤ 20	355	490	620	19	-	22	-	-	34	-	-	24	-	-					
			>20 ≤ 25	355	490	620	19	-	22	-	-	34	-	-	24	-	-					
			>25 ≤ 35	355	490	620	19	-	22	-	-	34	-	-	24	-	-					
			>35 ≤ 50	355	490	620	19	-	22	-	-	34	-	-	24	-	-					
			>50 ≤ 70	355	490	620	19	-	22	-	-	41	-	-	27	-	-					
>70 ≤ 100		355	490	620	19	-	22	-	-	50	-	-	34	-	-							
EH36		8-60	>6.4 ≤ 12.5	355	490	620	19	-	22	-	-	34	-	-	24	-	-					
			>12.5 ≤ 20	355	490	620	19	-	22	-	-	34	-	-	24	-	-					
			>20 ≤ 25	355	490	620	19	-	22	-	-	34	-	-	24	-	-					
			>25 ≤ 35	355	490	620	19	-	22	-	-	34	-	-	24	-	-					
			>35 ≤ 50	355	490	620	19	-	22	-	-	34	-	-	24	-	-					
			>50 ≤ 70	355	490	620	19	-	22	-	-	41	-	-	27	-	-					
>70 ≤ 100		355	490	620	19	-	22	-	-	50	-	-	34	-	-							
ASTM A 529		50	8-25	≤ 25	345	450	690	18	-	21	-	-	-	-	-	-	-	-				
		55	8-25	≤ 25	380	485	690	17	-	20	-	-	-	-	-	-	-	-				
ASTM A 572 / ASME SA 572		42	6-120	≤ 40	290	415	-	20 <sup>b</sup>	-	24 <sup>b</sup>	-	-	-	-	-	-	-	-				
	> 40			290	415	-	20 <sup>b</sup>	-	24 <sup>b</sup>	-	-	-	-	-	-	-	-					
	50	8-120	≤ 40	345	450	-	18 <sup>b</sup>	-	21 <sup>b</sup>	-	-	-	-	-	-	-	-					
			> 40	345	450	-	18 <sup>b</sup>	-	21 <sup>b</sup>	-	-	-	-	-	-	-	-					
55	8-120	≤ 40	380	485	-	17 <sup>b</sup>	-	20 <sup>b</sup>	-	-	-	-	-	-	-	-						
		> 40	380	485	-	17 <sup>b</sup>	-	20 <sup>b</sup>	-	-	-	-	-	-	-	-						
ASTM A 573	65	6-40	≤ 13	240	450	530	20 <sup>f</sup>	-	23 <sup>f</sup>	-	-	-	-	-	-	-						
			> 13 ≤ 40	240	450	530	20 <sup>f</sup>	-	23 <sup>f</sup>	-	-	-	-	-	-	-						
	70	6-40	≤ 13	290	485	620	18 <sup>f</sup>	-	21 <sup>f</sup>	-	-	-	-	-	-	-						
			> 13 ≤ 40	290	485	620	18 <sup>f</sup>	-	21 <sup>f</sup>	-	-	-	-	-	-	-						
ASTM A 709	50	8-50	≤ 40	345	450	-	18 <sup>b</sup>	-	21 <sup>b</sup>	-	-	-	-	-	-	-						
			> 40	345	450	-	18 <sup>b</sup>	-	21 <sup>b</sup>	-	-	-	-	-	-	-						
JIS G 3101	SS - 490	6-120	≤ 5	285	490	610	-	19	-	-	-	-	-	-	-	-						
			> 5 < 16	285	490	610	15	-	-	-	-	-	-	-	-							
			> 16 < 40	275	490	610	19	-	-	-	-	-	-	-	-							
			> 40 ≤ 100	255	490	610	-	-	21 <sup>a</sup>	-	-	-	-	-	-							
			> 100	245	490	610	-	-	21 <sup>a</sup>	-	-	-	-	-	-							
JIS G 3106	SM 490 YA	5-120	≤ 5	365	490	610	-	19	-	-	-	-	-	-	-							
			> 5 ≤ 16	365	490	610	15	-	-	-	-	-	-	-								
			> 16 < 40	355	490	610	19	-	-	-	-	-	-	-								
			> 40 < 75	335	490	610	-	-	21	-	-	-	-	-								
			> 75 < 100	325	490	610	-	-	21	-	-	-	-	-								
	SM 490 YB	5-120	≤ 5	365	490	610	-	19	-	-	-	-	-	-								
			> 5 < 16	365	490	610	15	-	-	-	27 <sup>f</sup>	-	-	-								
			> 16 < 40	355	490	610	19	-	-	-	27	-	-	-								
			> 40 < 75	335	490	610	-	-	21	-	-	-	-	-								
			> 75 < 100	325	490	610	-	-	21	-	-	-	-	-								
SM 520 B	8-120	≤ 5	365	520	640	-	19	-	-	-	-	-	-									
		> 5 < 12	365	520	640	15	-	-	-	-	-	-	-									
		> 12 < 16	365	520	640	15	-	-	-	27	-	-	-									
		> 16 < 40	355	520	640	19	-	-	-	27	-	-	-									
		> 40 < 75	335	520	640	-	-	21	-	-	-	-	-									
JIS G 3106	SM 520 C	8-120	> 75 < 100	325	520	640	-	21	-	-	27	-	-	-								
			≤ 5	365	520	640	-	19	-	-	-	-	-									
			> 5 < 12	365	520	640	15	-	-	-	-	-	-									
			> 12 < 16	365	520	640	15	-	-	-	47	-	-									
			> 16 < 40	355	520	640	19	-	-	-	47	-	-									

General & Weldable Structural Steel - High Strength Steel (Yield Strength ± 320 - 400 Mpa)

SPECIFICATION	GRADE	Prod. Thick (mm)	Thick. Range (mm)	MECHANICAL PROPERTIES																GENERAL PURPOSE		
				TENSILE TEST								IMPACT TEST										
				YS (N/mm <sup>2</sup> )			TS (N/mm <sup>2</sup> )			TR		EL (%)		+20		0		-20			-40	
				Min	Max	200	80	50	5.65V <sub>50</sub>	AVG	AVG	AVG	AVG	AVG	AVG	AVG	AVG	AVG	AVG		AVG	
EN 10025-2:2004 (PERUBAHAN DARI TAHUN 1993)	S 355 JR + AR	6-120	< 3	355	510	680	-	16	-	-	27	-	-	-	-	-	-					
			> 3 ≤ 16	355	470	630	-	-	-	20	27	-	-	-	-	-	-					
			> 16 ≤ 40	345	470	630	-	-	-	20	27	-	-	-	-	-	-					
			> 40 ≤ 63	335	470	630	-	-	-	19	27	-	-	-	-	-	-					
			> 63 ≤ 80	325	470	630	-	-	-	18	27	-	-	-	-	-	-					
			> 80 ≤ 100	315	470	630	-	-	-	18	27	-	-	-	-	-	-					
	S 355 JO + AR	6-120	< 3	355	510	680	-	16	-	-	27	-	-	-	-	-	-					
			> 3 ≤ 16	355	470	630	-	-	-	20	27	-	-	-	-	-						
			> 16 ≤ 40	345	470	630	-	-	-	20	27											

General & Weldable Structural Steel - High Strength Steel (Yield Strength ± 400 - 500 Mpa)

SPECIFICATION	GRADE	Prod. Thick (mm)	Thick. Range (mm)	MECHANICAL PROPERTIES																GENERAL PURPOSE
				TENSILE TEST								IMPACT TEST								
				TR				LG				TR				TR				
				YS (N/mm <sup>2</sup> )		TS (N/mm <sup>2</sup> )		EL (%)		5.65vSo		+20	0	-20	-40	+20	0	-20	-40	
AS 3678 (2016)	350	8-100	≤ 8	360	450	-	-	-	-	20	-	-	-	-	-	-	-	Hot Rolled Steel Plates		
			> 8 ≤ 12	360	450	-	-	-	20	-	-	-	-	-	-	-	-			
			> 12 ≤ 20	350	450	-	-	-	20	-	-	-	-	-	-	-	-		-	
			> 20 ≤ 32	340	450	-	-	-	20	-	-	-	-	-	-	-	-		-	
			> 32 ≤ 50	340	450	-	-	-	20	-	-	-	-	-	-	-	-		-	
			> 50 ≤ 80	340	450	-	-	-	20	-	-	-	-	-	-	-	-		-	
ASTM A 131	DH40	8-70	> 6.4 ≤ 12.5	390	510	650	19	-	22	-	-	-	39	-	-	26	-	Structural Steel for Ships		
			> 12.5 ≤ 20	390	510	650	19	-	22	-	-	-	39	-	-	26	-			
			> 20 ≤ 25	390	510	650	19	-	22	-	-	-	39	-	-	26	-			
			> 25 ≤ 35	390	510	650	19	-	22	-	-	-	39	-	-	26	-			
			> 35 ≤ 50	390	510	650	19	-	22	-	-	-	39	-	-	26	-			
			> 50 ≤ 70	390	510	650	19	-	22	-	-	-	46	-	-	31	-			
	EH40	8-70	> 70 ≤ 100	390	510	650	19	-	22	-	-	55	-	-	37	-	-	Structural Steel for Ships		
			> 6.4 ≤ 12.5	390	510	650	19	-	22	-	-	-	39	-	-	26	-			
			> 12.5 ≤ 20	390	510	650	19	-	22	-	-	-	39	-	-	26	-			
			> 20 ≤ 25	390	510	650	19	-	22	-	-	-	39	-	-	26	-			
			> 25 ≤ 35	390	510	650	19	-	22	-	-	-	39	-	-	26	-			
			> 35 ≤ 50	390	510	650	19	-	22	-	-	-	46	-	-	31	-			
ASTM A 572	60	6-40	≤ 40	415	520	-	-	16 <sup>M</sup>	-	-	18 <sup>M</sup>	-	-	-	-	-	-	High Strength Low Alloy Columbium-Vanadium Structural Steel		
			> 40	415	520	-	-	16 <sup>M</sup>	-	-	18 <sup>M</sup>	-	-	-	-	-				
			> 40	450	550	-	-	15 <sup>*</sup>	-	-	17 <sup>*</sup>	-	-	-	-	-				
	65	6-40	> 40	450	550	-	-	15 <sup>*</sup>	-	-	17 <sup>*</sup>	-	-	-	-	-				
			> 40	450	550	-	-	15 <sup>*</sup>	-	-	17 <sup>*</sup>	-	-	-	-	-				
			> 40	450	550	-	-	15 <sup>*</sup>	-	-	17 <sup>*</sup>	-	-	-	-	-				
JIS G 3101	SS-540	8-40	≤ 5	400	540	-	-	16	-	-	-	-	-	-	-	-	Hot Rolled Steel for General Structure			
			> 5 ≤ 16	400	540	-	-	13	-	-	-	-	-	-	-	-				
			> 16 ≤ 40	390	540	-	-	17	-	-	-	-	-	-	-	-				
JIS G 3106	SM 570	8-40	≤ 5	460	570	720	-	-	19	-	-	-	-	-	-	-	Hot Rolled Steel for Weldable Structure			
			> 5 ≤ 16	460	570	720	-	-	19	-	-	47 <sup>7</sup>	-	-	-	-				
			> 16 ≤ 50	450	570	720	-	-	19	-	-	47	-	-	-	-				
			> 50 ≤ 75	430	570	720	-	-	20	-	-	47	-	-	-	-				
			> 75 ≤ 100	420	570	720	-	-	20	-	-	47	-	-	-	-				
EN 10025-4:2004	S 420 M	8-40	≤ 16	420	520	680	-	-	17	55	47	40	-	31	27	20	-	WELDABLE FINE GRAIN STRUCTURAL STEEL		
			> 16 ≤ 30	400	520	680	-	-	17	55	47	40	-	31	27	20	-			
			> 30 ≤ 40	400	520	680	-	-	17	55	47	40	-	31	27	20	-			
			> 40 ≤ 63	390	500	660	-	-	17	55	47	40	-	31	27	20	-			
			> 63 ≤ 100	380	480	640	-	-	17	55	47	40	-	31	27	20	-			
			> 100 ≤ 150	365	460	620	-	-	17	55	47	40	-	31	27	20	-			
	S 420 ML	8-40	> 16 ≤ 30	400	520	680	-	-	17	63	55	47	31	40	34	27	20	WELDABLE FINE GRAIN STRUCTURAL STEEL		
			> 30 ≤ 40	400	520	680	-	-	17	63	55	47	31	40	34	27	20			
			> 40 ≤ 63	390	500	660	-	-	17	63	55	47	31	40	34	27	20			
			> 63 ≤ 100	380	480	640	-	-	17	63	55	47	31	40	34	27	20			
			> 100 ≤ 150	365	460	620	-	-	17	63	55	47	31	40	34	27	20			
			> 150 ≤ 200	350	450	610	-	-	17	63	55	47	31	40	34	27	20			
EN 10025-4 (2004)	S 460 M	18-40	≤ 16	440	540	720	-	-	17	55	47	40	-	-	-	-	Weldable fine grain structural steel			
			> 16 ≤ 30	440	540	720	-	-	17	55	47	40	-	-	-	-				
			> 30 ≤ 40	430	540	720	-	-	17	55	47	40	-	-	-	-				
	> 40 ≤ 63	410	540	720	-	-	17	55	47	40	-	-	-	-						
	> 63 ≤ 100	400	540	720	-	-	17	55	47	40	-	-	-	-						
	> 100 ≤ 150	380	530	710	-	-	17	55	47	40	-	-	-	-						
AS3678 (2016)	400	8-40	≤ 8	400	480	-	-	18	-	-	-	-	-	-	-	-	Hot Rolled Steels - Plates			
			> 8 ≤ 12	400	480	-	-	18	-	-	-	-	-	-	-	-				
			> 12 ≤ 20	380	480	-	-	18	-	-	-	-	-	-	-	-				
			> 20 ≤ 32	360	480	-	-	18	-	-	-	-	-	-	-	-				
			> 32 ≤ 50	360	480	-	-	18	-	-	-	-	-	-	-	-				
			> 50 ≤ 80	360	480	-	-	18	-	-	-	-	-	-	-	-				
BS 4360 (1986)	55 C	8-40	≤ 16	450	550	700	17	19	-	19	-	27	-	-	-	-	Weldable Structural Steels			
			> 16 ≤ 40	430	550	700	17	19	-	19	-	27	-	-	-	-				
			> 40 ≤ 63	430	550	700	17	19	-	19	-	27	-	-	-	-				
			> 63 ≤ 100	430	550	700	17	19	-	19	-	27	-	-	-	-				
			> 100 ≤ 150	430	550	700	17	19	-	19	-	27	-	-	-	-				
			> 150 ≤ 200	430	550	700	17	19	-	19	-	27	-	-	-	-				
	55 EE	8-40	> 16 ≤ 40	430	550	700	17	19	-	19	-	27	-	-	-	-	Weldable Structural Steels			
			> 40 ≤ 63	430	550	700	17	19	-	19	-	27	-	-	-	-				
			> 63 ≤ 100	430	550	700	17	19	-	19	-	27	-	-	-	-				
			> 100 ≤ 150	430	550	700	17	19	-	19	-	27	-	-	-	-				
			> 150 ≤ 200	430	550	700	17	19	-	19	-	27	-	-	-	-				
			> 200 ≤ 250	430	550	700	17	19	-	19	-	27	-	-	-	-				

Pressure Vessel - Mild Steel

SPECIFICATION	GRADE	Prod. Thick (mm)	Thick. Range (mm)	MECHANICAL PROPERTIES																GENERAL PURPOSE
				TENSILE TEST								IMPACT TEST								
				TR				LG				TR				TR				
				YS (N/mm <sup>2</sup> )		TS (N/mm <sup>2</sup> )		EL (%)		5.65vSo		+20	0	-20	-40	+20	0	-20	-40	
ASTM A 285 / ASME SA 285	A	5-50	≤ 16	165	310	450	27	-	30	-	-	-	-	-	-	-	LOW AND INTERMEDIATE TENSILE STRENGTH PRESSURE VESSEL PLATES			
			> 16 ≤ 40	185	345	485	25	-	28	-	-	-	-	-	-	-				
			> 40 ≤ 80	205	380	515	23	-	27	-	-	-	-	-	-	-				
ASME SA 516	55	5-80	≤ 12.5	205	380	515	23	-	27	-	-	-	-	-	-	-	PRESSURE VESSEL PLATES, CARBON STEEL FOR MODERATE AND LOW TEMPERATURE SERVICE			
			> 12.5 ≤ 50	205	380	515	23	-	27	-	-	-	-	-	-					
			> 50 ≤ 100	205	380	515	23	-	27	-	-	-	-	-	-					
	60	5-80	≤ 12.5	220	415	550	21	-	25	-	-	-	-	-	-	-				
			> 12.5 ≤ 50	220	415	550	21	-	25	-	-	-	-	-	-					
			> 50 ≤ 100	220	415	550	21	-	25	-	-	-	-	-	-					
EN 10028	P 235 GH	6-80	≤ 16	235	360	480	-	-	24	40	34	27	-	-	-	-	WELDABLE FINE GRAIN STEELS FOR PRESSURE PURPOSES			
			> 16 ≤ 40	225	360	480	-	-	24	40	34	27	-	-	-					
			> 40 ≤ 60	215	360	480	-	-	24	40	34	27	-	-	-					
	P 265 GH	6-80	≤ 16	265	410	530	-	-	22	40	34	27	-	-	-	-				
			> 16 ≤ 40	255	410	530	-	-	22	40	34	27	-	-	-					
			> 40 ≤ 60	245	410	530	-	-	22	40	34	27	-	-	-					
EN 10028-3 (2009)	P 275 NH	6-80	≤ 16	275	390	510	-	-	24	75	65	45	-	50	40	30	-			
			> 16 ≤ 40	265	390	510	-	-	24	75	65	45	-	50	40	30	-			
			> 40 ≤ 60	255	390	510	-	-	24	75	65	45	-	50	40	30	-			
	P 275 NL1	6-80	≤ 16	275	390	510	-	-	24	80	70	50	40	60	50	35	27			
			> 16 ≤ 40	265	390	510	-	-	24	80	70	50	40	60	50					

Pressure Vessel - High Strength Steel (Yield Strength ± 400 - 500 Mpa)

SPECIFICATION	GRADE	Prod. Thick (mm)	Thick. Range (mm)	MECHANICAL PROPERTIES														GENERAL PURPOSE
				TENSILE TEST							IMPACT TEST							
				TR			EL (%)				LG				TR			
				YS (N/mm <sup>2</sup> )	TS (N/mm <sup>2</sup> )						+20	0	-20	-40	+20	0	-20	
Min	Min	Max	200	80	50	5.65v <sub>50</sub>	AVG	AVG	AVG	AVG	AVG	AVG	AVG	AVG	AVG			
EN 10028-5 (2009)	P 420 M	8-63	≤ 16	420	500	660	-	-	-	19	-	-	-	60	40	27	-	WELDABLE FINE GRAIN STEELS FOR PRESSURE PURPOSES
			> 16 ≤ 40	400	500	660	-	-	-	19	-	-	-	-	-	-	-	
			> 40 ≤ 63	390	500	660	-	-	-	19	-	-	-	-	-	-	-	
	P 420 ML1	8-63	≤ 16	420	500	660	-	-	-	19	-	-	-	60	40	27	-	WELDABLE FINE GRAIN STEELS FOR PRESSURE PURPOSES
			> 16 ≤ 40	400	500	660	-	-	-	19	-	-	-	-	-	-		
			> 40 ≤ 63	390	500	660	-	-	-	19	-	-	-	-	-	-		
	P 460 M	8-40	≤ 16	460	530	720	-	-	-	17	-	-	-	60	40	27	-	WELDABLE FINE GRAIN STEELS FOR PRESSURE PURPOSES
			> 16 ≤ 40	440	530	720	-	-	-	17	-	-	-	-	-	-		
			> 40 ≤ 63	390	500	660	-	-	-	19	-	-	-	-	-	-		
	P 460 ML1	8-40	≤ 16	460	530	720	-	-	-	17	-	-	-	60	40	27	-	WELDABLE FINE GRAIN STEELS FOR PRESSURE PURPOSES
			> 16 ≤ 40	440	530	720	-	-	-	17	-	-	-	-	-	-		
			> 40 ≤ 63	390	500	660	-	-	-	19	-	-	-	-	-	-		

Line Pipe Steel - High Strength Steel (Yield Strength ± 320 - 400 Mpa)

SPECIFICATION	GRADE	Prod. Thick (mm)	Thick. Range (mm)	MECHANICAL PROPERTIES														GENERAL PURPOSE
				TENSILE TEST							IMPACT TEST							
				TR			EL (%)				LG				TR			
				YS (N/mm <sup>2</sup> )	TS (N/mm <sup>2</sup> )						+20	0	-20	-40	+20	0	-20	
Min	Min	Max	200	80	50	5.65v <sub>50</sub>	AVG	AVG	AVG	AVG	AVG	AVG	AVG	AVG	AVG			
API 5L PSL 1 Welded Pipe	X 46	8-25	≤ 25	320-525	4357	60	---	-4	0	-	-	-	-	-	-	-	LINE PIPE STEEL	
	X 52	8-25	≤ 25	360-530	4607	60	---	-4	0	-	-	-	-	-	-	-		
	X 56	8-25	≤ 25	390-545	4907	60	---	-4	0	-	-	-	-	-	-	-		
API 5L PSL 2 Welded Pipe	X 46M	8-25	≤ 25	320-525	4357	60	---	-4	0	-	-	-	-	-	-	-	LINE PIPE STEEL	
	X 52M	8-25	≤ 25	360-530	4607	60	---	-4	0	-	-	-	-	-	-	-		
	X 56M	8-25	≤ 25	390-545	4907	60	---	-4	0	-	-	-	-	-	-	-		

Line Pipe Steel - High Strength Steel (Yield Strength ± 400 - 500 Mpa)

SPECIFICATION	GRADE	Prod. Thick (mm)	Thick. Range (mm)	MECHANICAL PROPERTIES														GENERAL PURPOSE
				TENSILE TEST							IMPACT TEST							
				TR			EL (%)				LG				TR			
				YS (N/mm <sup>2</sup> )	TS (N/mm <sup>2</sup> )						+20	0	-20	-40	+20	0	-20	
Min	Min	Max	200	80	50	5.65v <sub>50</sub>	AVG	AVG	AVG	AVG	AVG	AVG	AVG	AVG	AVG			
API 5L PSL 1	X 60	8-25	≤ 25	415-565	5207	60	---	-4	0	-	-	-	-	-	-	-	PIPELINE STEEL	
	X 65	8-25	≤ 25	450-600	5357	60	---	-4	0	-	-	-	-	-	-	-		
	X 70	8-25	≤ 25	485-635	5707	60	---	-4	0	-	-	-	-	-	-	-		
API 5L PSL 2	X 60M8	-25	≤ 25	415-565	5207	60	---	-4	0	-	-	-	-	-	-	-	PIPELINE STEEL	
	X 65M8	-25	≤ 25	450-600	5357	60	---	-4	0	-	-	-	-	-	-	-		
	X 70M8	-25	≤ 25	485-635	5707	60	---	-4	0	-	-	-	-	-	-	-		

Weather Resistant Steel - Mild Steel

SPECIFICATION	GRADE	Prod. Thick (mm)	Thick. Range (mm)	MECHANICAL PROPERTIES														GENERAL PURPOSE
				TENSILE TEST							IMPACT TEST							
				TR			EL (%)				LG				TR			
				YS (N/mm <sup>2</sup> )	TS (N/mm <sup>2</sup> )						+20	0	-20	-40	+20	0	-20	
Min	Min	Max	200	80	50	5.65v <sub>50</sub>	AVG	AVG	AVG	AVG	AVG	AVG	AVG	AVG	AVG			
JIS 3114:2008	SMA400AW	6-150	≤ 8	245	400	540	22	-	-	-	-	-	-	-	-	-	-	HOT ROLLED ATMOSPHERIC CORROSION RESISTING STEELS FOR WELDED STRUCTURE
			> 8 ≤ 16	245	400	540	17	-	-	-	-	-	-	-	-	-		
			> 16 ≤ 40	235	400	540	21	-	-	-	-	-	-	-	-	-		
			> 40 ≤ 63	215	400	540	21	-	-	-	-	-	-	-	-	-		
			> 63 ≤ 80	215	400	540	-	23	-	-	-	-	-	-	-	-		
			> 80 ≤ 100	215	400	540	-	23	-	-	-	-	-	-	-	-		
	SMA400AP	6-150	≤ 8	245	400	540	22	-	-	-	-	-	-	-	-	-	-	HOT ROLLED ATMOSPHERIC CORROSION RESISTING STEELS FOR WELDED STRUCTURE
			> 8 ≤ 16	245	400	540	17	-	-	-	-	-	-	-	-			
			> 16 ≤ 40	235	400	540	21	-	-	-	-	-	-	-	-			
			> 40 ≤ 63	215	400	540	-	23	-	-	-	-	-	-	-			
			> 63 ≤ 80	215	400	540	-	23	-	-	-	-	-	-	-			
			> 80 ≤ 100	205	400	540	-	23	-	-	-	-	-	-	-			
SMA400BW	6-150	≤ 8	245	400	540	22	-	-	-	-	-	-	-	-	-	-	HOT ROLLED ATMOSPHERIC CORROSION RESISTING STEELS FOR WELDED STRUCTURE	
		> 8 ≤ 16	245	400	540	17	-	-	-	-	-	-	-	-				
		> 16 ≤ 40	235	400	540	21	-	-	-	-	-	-	-	-				
		> 40 ≤ 63	215	400	540	-	23	-	-	-	-	-	-	-				
		> 63 ≤ 80	215	400	540	-	23	-	-	-	-	-	-	-				
		> 80 ≤ 100	205	400	540	-	23	-	-	-	-	-	-	-				
SMA400BP	6-150	≤ 8	245	400	540	22	-	-	-	-	-	-	-	-	-	-	HOT ROLLED ATMOSPHERIC CORROSION RESISTING STEELS FOR WELDED STRUCTURE	
		> 8 ≤ 16	245	400	540	17	-	-	-	-	-	-	-	-				
		> 16 ≤ 40	235	400	540	21	-	-	-	-	-	-	-	-				
		> 40 ≤ 63	215	400	540	-	23	-	-	-	-	-	-	-				
		> 63 ≤ 80	215	400	540	-	23	-	-	-	-	-	-	-				
		> 80 ≤ 100	205	400	540	-	23	-	-	-	-	-	-	-				
SMA400CW	6-150	≤ 8	245	400	540	22	-	-	-	-	-	-	-	-	-	-	HOT ROLLED ATMOSPHERIC CORROSION RESISTING STEELS FOR WELDED STRUCTURE	
		> 8 ≤ 16	245	400	540	17	-	-	-	-	-	-	-	-				
		> 16 ≤ 40	235	400	540	21	-	-	-	-	-	-	-	-				
		> 40 ≤ 63	215	400	540	-	23	-	-	-	-	-	-	-				
		> 63 ≤ 80	215	400	540	-	23	-	-	-	-	-	-	-				
		> 80 ≤ 100	205	400	540	-	23	-	-	-	-	-	-	-				
SMA400CP	6-150	≤ 8	245	400	540	22	-	-	-	-	-	-	-	-	-	-	HOT ROLLED ATMOSPHERIC CORROSION RESISTING STEELS FOR WELDED STRUCTURE	
		> 8 ≤ 16	245	400	540	17	-	-	-	-	-	-	-	-				
		> 16 ≤ 40	235	400	540	21	-	-	-	-	-	-	-	-				
		> 40 ≤ 63	215	400	540	-	23	-	-	-	-	-	-	-				
		> 63 ≤ 80	215	400	540	-	23	-	-	-	-	-	-	-				
		> 80 ≤ 100	215	400	540	-	23	-	-	-	-	-	-	-				

Weather Resistant Steel - High Strength Steel

SPECIFICATION	GRADE	Prod. Thick (mm)	Thick. Range (mm)	MECHANICAL PROPERTIES														GENERAL PURPOSE
				TENSILE TEST							IMPACT TEST							
				TR			EL (%)				LG				TR			
				YS (N/mm <sup>2</sup> )	TS (N/mm <sup>2</sup> )						+20	0	-20	-40	+20	0	-20	
Min	Min	Max	200	80	50	5.65v <sub>50</sub>	AVG	AVG	AVG	AVG	AVG	AVG	AVG	AVG	AVG			
ASTM A588	Gr. A	8-120	≤ 100	345	485	-	18	-	21	-	-	-	-	-	-	-	HIGH STRENGTH LOW-ALLOY STRUCTURAL STEEL WITH ATMOSPHERIC CORROSION RESISTANCE	
			> 100 ≤ 125	315	460	-	-	-	21	-	-	-	-	-	-			
			> 125 ≤ 150	290	435	-	-	-	21	-	-	-	-	-	-			
	Gr. B	8-120	≤ 100	345	485	-	18	-	21	-	-	-	-	-	-	-	HIGH STRENGTH LOW-ALLOY STRUCTURAL STEEL WITH ATMOSPHERIC CORROSION RESISTANCE	
			> 100 ≤ 125	315	460	-	-	-	21	-	-	-	-	-	-			
			> 125 ≤ 150	290	435	-	-	-	21	-	-	-	-	-	-			
	Gr. K	8-120	≤ 100	345	485	-	18	-	21	-	-	-	-	-	-	-	HIGH STRENGTH LOW-ALLOY STRUCTURAL STEEL WITH ATMOSPHERIC CORROSION RESISTANCE	
			> 100 ≤ 125	315	460	-	-	-	21	-	-	-	-	-	-			
			> 125 ≤ 150	290	435	-	-	-	21	-	-	-	-	-	-			
	SMA490AW	8-120	≤ 5	365	490	610	-	19	-	-	-	-	-	-	-	-	-	HOT ROLLED ATMOSPHERIC CORROSION RESISTING STEELS FOR WELDED STRUCTURE
			> 5 ≤ 16	365	490	610	15	-	-	-	-	-	-	-	-			
			> 16 ≤ 40	355	490	610	15	-	-	-	-	-	-	-	-			
> 40 ≤ 50			335	490	610	19	-	-	-	-	-	-	-	-				
> 50 ≤ 75			335	490	610	19	-	-	-	-	-	-	-	-				
> 75 ≤ 100			325	490	610	-	21	-	-	-	-	-	-	-				
SMA490AP		8-120	≤ 5	365	490	610	-	19	-	-	-	-	-	-	-	-	HOT ROLLED ATMOSPHERIC CORROSION RESISTING STEELS FOR WELDED STRUCTURE	
			> 5 ≤ 16	365	490	610	15	-	-	-	-	-						





## Hot Rolled Coil

We can also supply flat products in coil form, whether it is hot-rolled or cold-rolled. Our hot rolled coils have excellent formability and weldability. On the other hand, our cold rolled coils offer superior surface quality, mechanical property, and precise dimensions.

Our hot rolled coils are produced by heating the best steel slabs we can source over the recrystallization temperature, rolled into desired thickness, and coiled at high temperature.

Applications of our hot rolled coils include welded steel structural beams, forming application, storage tanks, boilers, flanges, gas cylinders, and welded pipe.



**Standard & Specification:**  
 ASTM A-36  
 ASTM A-572  
 JIS G 3101  
 JIS G 3131

**Available Size:**  
 Thickness 2mm - 25mm  
 Width 900mm - 1524mm  
 Maximum 25 MT/Coil

**Annual Capacity:**  
 720.000 MT/Year  
 (for coil production only)

### Forming (Commercial Or Drawing Quality)

SPECIFICATION	GRADE	Prod. Thick (mm)	Thick. Range (mm)	MECHANICAL PROPERTIES													GENERAL PURPOSE
				TENSILE TEST						IMPACT TEST							
				TR			EL (%)			LG		TR					
YS (N/mm <sup>2</sup> )	TS (N/mm <sup>2</sup> )		EL (%)			+20	0	-20	-40	+20	0	-20	-40				
Min	Min	Max	200	80	50	5.65S <sub>0</sub>	AVG	AVG	AVG	AVG	AVG	AVG	AVG	AVG			
ASTM A830	1006	≤ 25	-	-	-	-	-	-	-	-	-	-	-	-	-	CARBON STEEL	
	1008	≤ 25	-	-	-	-	-	-	-	-	-	-	-	-	-		
A1011 CS	Type A	≤ 6	≤ 6	-	-	-	-	-	-	-	-	-	-	-	-	Hot rolled steel sheet and strip, Commercial Steel	
	Type B	≤ 6	≤ 6	-	-	-	-	-	-	-	-	-	-	-	-		
	Type C	≤ 6	≤ 6	-	-	-	-	-	-	-	-	-	-	-	-		
	Type D	≤ 6	≤ 6	-	-	-	-	-	-	-	-	-	-	-	-		
A1011 DS	Type A	≤ 6	≤ 6	-	-	-	-	-	-	-	-	-	-	-	-	Hot rolled steel sheet and strip, Drawing Steel	
	Type B	≤ 6	≤ 6	-	-	-	-	-	-	-	-	-	-	-	-		
SAPH 400 (41)			≥ 1.6 < 2	-	-	-	-	-	-	-	-	-	-	-	-	Hot rolled steel plate, sheet and strip for automobile structural uses	
			≥ 2 < 2.5	-	-	-	-	-	-	-	-	-	-	-	-		
			≥ 2.5 < 3.15	-	-	-	-	-	-	-	-	-	-	-	-		
			≥ 3.15 < 4	-	-	-	-	-	-	-	-	-	-	-	-		
			≥ 4 < 6	-	-	-	-	-	-	-	-	-	-	-	-		
JIS G 3113-2006			≥ 6 < 6.3	-	-	-	-	-	-	-	-	-	-	-	-	Hot rolled steel plate, sheet and strip for automobile structural uses	
			≥ 6.3 < 8	-	-	-	-	-	-	-	-	-	-	-	-		
			≥ 8 < 14	-	-	-	-	-	-	-	-	-	-	-	-		
			≥ 1.6 < 2	-	-	-	-	-	-	-	-	-	-	-	-		
			≥ 2 < 2.5	-	-	-	-	-	-	-	-	-	-	-	-		
SAPH 440 (45)			≥ 2.5 < 3.15	-	-	-	-	-	-	-	-	-	-	-	-	Hot rolled mild steel plates, sheet and strip	
			≥ 3.15 < 4	-	-	-	-	-	-	-	-	-	-	-	-		
			≥ 4 < 6	-	-	-	-	-	-	-	-	-	-	-	-		
			≥ 6 < 6.3	-	-	-	-	-	-	-	-	-	-	-	-		
			≥ 6.3 < 8	-	-	-	-	-	-	-	-	-	-	-	-		
JIS G 3131-2010			≥ 8 < 14	-	-	-	-	-	-	-	-	-	-	-	-	Hot rolled mild steel plates, sheet and strip	
			≥ 1.6 < 2	-	-	-	-	-	-	-	-	-	-	-	-		
			≥ 2 < 2.5	-	-	-	-	-	-	-	-	-	-	-	-		
			≥ 2.5 < 3.2	-	-	-	-	-	-	-	-	-	-	-	-		
			≥ 3.2 < 4	-	-	-	-	-	-	-	-	-	-	-	-		
SPHC			≥ 4	-	-	-	-	-	-	-	-	-	-	-	-	Hot rolled mild steel plates, sheet and strip	
			≥ 1.2 < 1.6	-	-	-	-	-	-	-	-	-	-	-	-		
			≥ 1.6 < 2	-	-	-	-	-	-	-	-	-	-	-	-		
			≥ 2 < 2.5	-	-	-	-	-	-	-	-	-	-	-	-		
			≥ 2.5 < 3.2	-	-	-	-	-	-	-	-	-	-	-	-		
JIS G 3131-2010			≥ 3.2 < 4	-	-	-	-	-	-	-	-	-	-	-	-	Hot rolled mild steel plates, sheet and strip	
			≥ 4	-	-	-	-	-	-	-	-	-	-	-	-		
			≥ 1.2 < 1.6	-	-	-	-	-	-	-	-	-	-	-	-		
			≥ 1.6 < 2	-	-	-	-	-	-	-	-	-	-	-	-		
			≥ 2 < 2.5	-	-	-	-	-	-	-	-	-	-	-	-		
SPHD			≥ 2.5 < 3.2	-	-	-	-	-	-	-	-	-	-	-	-	Hot rolled carbon steel strip for pipes and tubes	
			≥ 3.2 < 4	-	-	-	-	-	-	-	-	-	-	-	-		
			≥ 4	-	-	-	-	-	-	-	-	-	-	-	-		
			≥ 1.2 < 1.6	-	-	-	-	-	-	-	-	-	-	-	-		
			≥ 1.6 < 2	-	-	-	-	-	-	-	-	-	-	-	-		
JIS G 3132			≥ 2 < 2.5	-	-	-	-	-	-	-	-	-	-	-	-	Hot rolled carbon steel strip for pipes and tubes	
			≥ 2.5 < 3.2	-	-	-	-	-	-	-	-	-	-	-	-		
			≥ 3.2 < 4	-	-	-	-	-	-	-	-	-	-	-	-		
			≥ 4	-	-	-	-	-	-	-	-	-	-	-	-		
			≥ 1.2 < 1.6	-	-	-	-	-	-	-	-	-	-	-	-		
SPHT-1			≥ 1.6 < 3	-	-	-	-	-	-	-	-	-	-	-	-	Hot rolled carbon steel strip for pipes and tubes	
			≥ 3 < 6	-	-	-	-	-	-	-	-	-	-	-	-		
			≥ 6 < 13	-	-	-	-	-	-	-	-	-	-	-	-		
			≥ 1.2 < 1.6	-	-	-	-	-	-	-	-	-	-	-	-		
			≥ 1.6 < 3	-	-	-	-	-	-	-	-	-	-	-	-		
SPHT-2			≥ 3 < 6	-	-	-	-	-	-	-	-	-	-	-	-	Hot rolled carbon steel strip for pipes and tubes	
			≥ 6 < 13	-	-	-	-	-	-	-	-	-	-	-	-		
			≥ 1.2 < 1.6	-	-	-	-	-	-	-	-	-	-	-	-		
			≥ 1.6 < 3	-	-	-	-	-	-	-	-	-	-	-	-		
			≥ 3 < 6	-	-	-	-	-	-	-	-	-	-	-	-		
SPHT-3			≥ 6 < 13	-	-	-	-	-	-	-	-	-	-	-	-	Hot rolled carbon steel strip for pipes and tubes	
			≥ 1.2 < 1.6	-	-	-	-	-	-	-	-	-	-	-	-		
			≥ 1.6 < 3	-	-	-	-	-	-	-	-	-	-	-	-		
			≥ 3 < 6	-	-	-	-	-	-	-	-	-	-	-	-		
			≥ 6 < 13	-	-	-	-	-	-	-	-	-	-	-	-		









## Coil Plate

We produce Steel Coil Plate with our proprietary technology to guarantee the best quality product results. Our Coil Plate comes with a variety of standards and sizes that can be tailored to your needs.

GRP uses equalizing process to produce highest standard of coil plate, this industry leading standard produces a quality steel plate that is consistently flat.

**Standard & Specification:**  
A36, SS400, A283, EN 10025 Gr.235 JR, A572Gr50.

**Available Size:**  
Thickness 2.0mm – 12mm  
Width 900 – 1524 mm

**Annual Capacity:**  
360.000 MT/Year



### High Strength Steel YS>300 Mpa

SPECIFICATION	GRADE	Prod. Thick (mm)	MECHANICAL PROPERTIES				
			Tensile Testing			Impact Testing (CVN)	
			YS (MPa)	TS (MPa)	EL (%)	LG	TR
ASTM A 131 / ASME SA 131	AH36	6 - 10	355	490 - 620	19	0°C (27 Joule)	0°C (24 Joule)
	DH36	6 - 10	355	490 - 620	19	-20°C (27 Joule)	-20°C (24 Joule)
	EH36	6 - 10	355	490 - 620	19	-40°C (27 Joule)	-40°C (24 Joule)
	AH40	6 - 10	390	510 - 650	19	0°C (39 Joule)	0°C (26 Joule)
	DH40	6 - 10	390	510 - 650	19	-20°C (39 Joule)	-20°C (26 Joule)
ASTM A 572 / ASME SA 527	50	6 - 10	345	450	18M	-	-
	55	6 - 10	380	485	17M	-	-
	60	6 - 10	415	520	16M	-	-
ASTM A 573 / ASME SA 573	70	6 - 10	290	485 - 620	18R	-	-
JIS G 3101	SS 490	6 - 10	285	490 - 610	15	-	-
	SS 540	6 - 10	400	540	13	-	-
JIS G 3106	SM 490 A	6 - 10	325	490 - 610	17	-	-
	SM 490 B	6 - 10	325	490 - 610	17	0°C (27 Joule)	-
	SM 490 C	6 - 10	325	490 - 610	17	0°C (47 Joule)	-
	SM 490 YA	6 - 10	365	490 - 610	15	-	-
	SM 490 YB	6 - 10	365	490 - 610	15	0°C (27 Joule)	-
	SM 520 B	6 - 10	365	520 - 640	15	0°C (27 Joule)	-
BS 4360	50 B	6 - 10	355	490 - 640	18C	+20°C (27 Joule)	-
	50 C	6 - 10	355	490 - 640	18C	0°C (27 Joule)	-
	50 D	6 - 10	355	490 - 640	18C	-20°C (47 Joule)	-
	50 DD	6 - 10	355	490 - 640	18C	-30°C (47 Joule)	-
EN 10025-2 / MS EN 10025-2	S 355 JR	6 - 10	355	470 - 630	20	+20°C (27 Joule)	-
	S 355 J0	6 - 10	355	470 - 630	20	0°C (27 Joule)	-
	S 355 J2	6 - 10	355	470 - 630	20	-20°C (47 Joule)	-
CSA G40.21 (1998)	350 W (50 W)	6 - 10	350	450 - 650	17	-	-
	400 W (60 W)	6 - 10	400	520 - 690	13	-	-
	1E-1863	6-100	345 - 500	450	16	-29°C (11 Joule)	-

**PRESSURE VESSEL STEEL**

SPECIFICATION	GRADE	Prod. Thick (mm)	MECHANICAL		
			Tensile Testing		
			YS (MPa)	TS (MPa)	EL (%)
ASTM A 516 / ASME SA 516	55	6 - 10	205	380 - 515	23
	60	6 - 10	220	415 - 550	21
	65	6 - 10	240	450 - 585	19
ASTM A 572 / ASME SA 527	70	6 - 10	260	485 - 620	17
	B	4 - 12	185	345 - 485	25
JIS G 3101	C	4 - 12	205	380 - 515	23
	SG 255	2 - 4	255	400	28
	SG 295	2 - 3	295	440	26

**WEATHER RESISTANT STEEL / Atmospheric Corrosion Resistance**

SPECIFICATION	GRADE	Prod. Thick (mm)	MECHANICAL		
			Tensile Testing		
			YS (MPa)	TS (MPa)	EL (%)
ASTM A 242 / ASME SA 242	-	6 - 10	345	480	18

**SHIP-BUILDING STEEL**

SPECIFICATION	GRADE	Prod. Thick (mm)	MECHANICAL PROPERTIES				
			Tensile Testing			Impact Testing (CVN)	
			YS (MPa)	TS (MPa)	EL (%)	LG	TR
Certified by LR, ABS, BV, BKI, & DNV GL	AH36	6 - 10	355	490 - 620	19	0°C (27 Joule)	0°C (24 Joule)
	DH36	6 - 10	355	490 - 620	19	-20°C (27 Joule)	-20°C (24 Joule)
	EH36	6 - 10	355	490 - 620	19	-40°C (27 Joule)	-40°C (24 Joule)
	AH40	6 - 10	390	510 - 650	19	0°C (39 Joule)	0°C (26 Joule)
	DH40	6 - 10	390	510 - 650	19	-20°C (39 Joule)	-20°C (26 Joule)
	EH40	6 - 10	390	510 - 650	19	-40°C (39 Joule)	-40°C (26 Joule)
	A	5-12	235	400 - 520	21	-	-
	B	5-12	235	400 - 520	21	0°C (27 Joule)	0°C (20 Joule)
	D	5-12	235	400 - 520	21	-20°C (27 Joule)	-20°C (20 Joule)
	E	5-12	235	400 - 520	21	-40°C (27 Joule)	-40°C (20 Joule)

**AVAILABLE SIZE**

	Thickness Range (mm)	Maximum Length (mm)		
		Width Range (mm)		
		900 - 1070	1070 - 1219	1219 - 1524
MILD STEEL (YS < 300 MPa)	2 - 3	4000	4000	-
	3 - 4.5	6000	6000	-
	4.5 - 6	12000	12000	12000
	6 - 8	12000	12000	12000
	8 - 9	12000	12000	12000
	9 - 12	12000	12000	12000

\*Minimum Length 2000 mm

	Thickness Range (mm)	Maximum Length (mm)		
		Width Range (mm)		
		900 - 1070	1070 - 1219	1219 - 1524
HIGH STRENGTH STEEL (YS > 300 MPa)	6 - 8	12000	12000	12000
	8 - 9	12000	12000	12000
	9 - 10	12000	12000	12000

\*Minimum Length 2000 mm



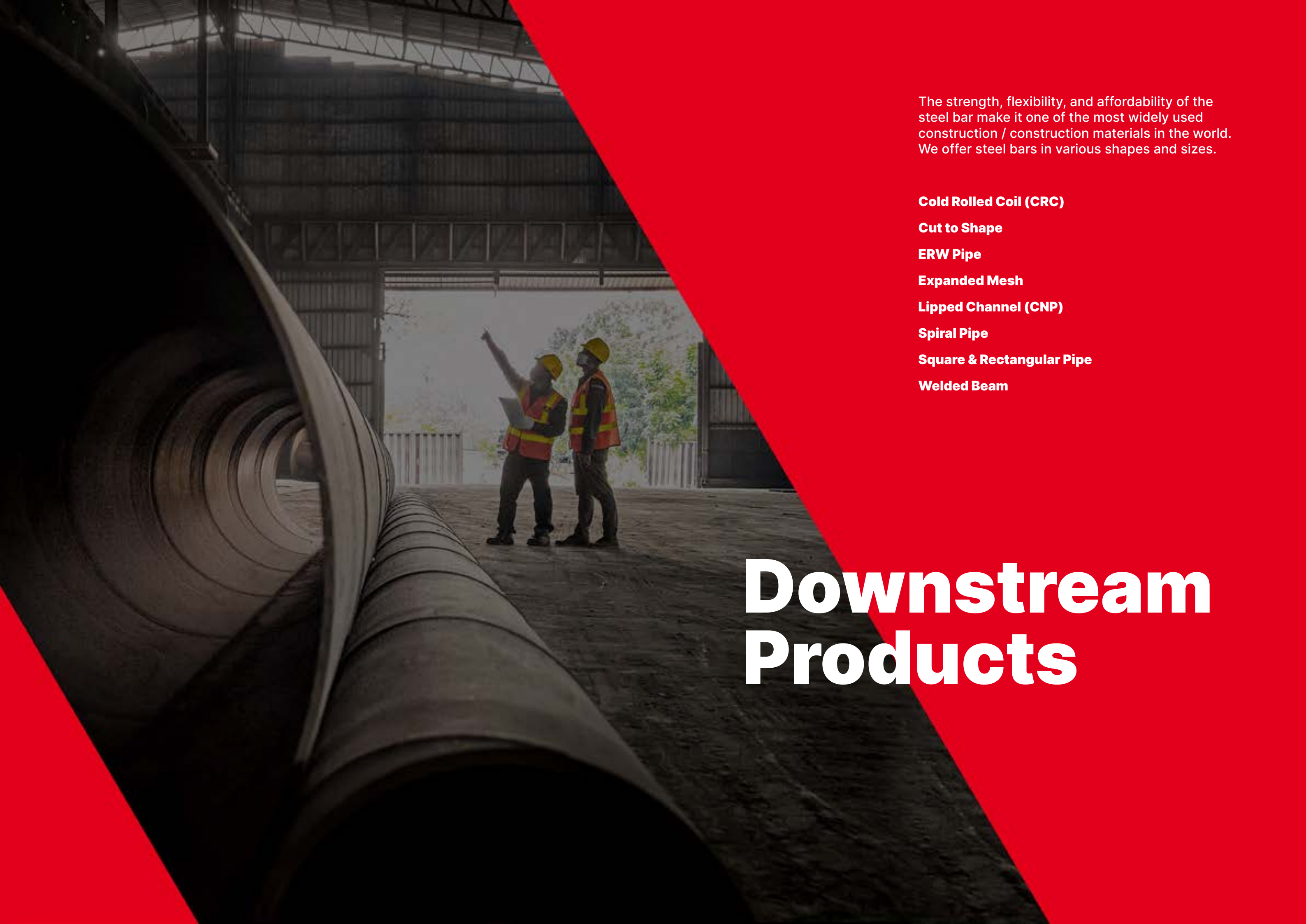

The strength, flexibility, and affordability of the steel bar make it one of the most widely used construction / construction materials in the world. We offer steel bars in various shapes and sizes.

**Cold Rolled Coil (CRC)**

**Cut to Shape**

**ERW Pipe**

**Expanded Mesh**

**Lipped Channel (CNP)**

**Spiral Pipe**

**Square & Rectangular Pipe**

**Welded Beam**

# Downstream Products

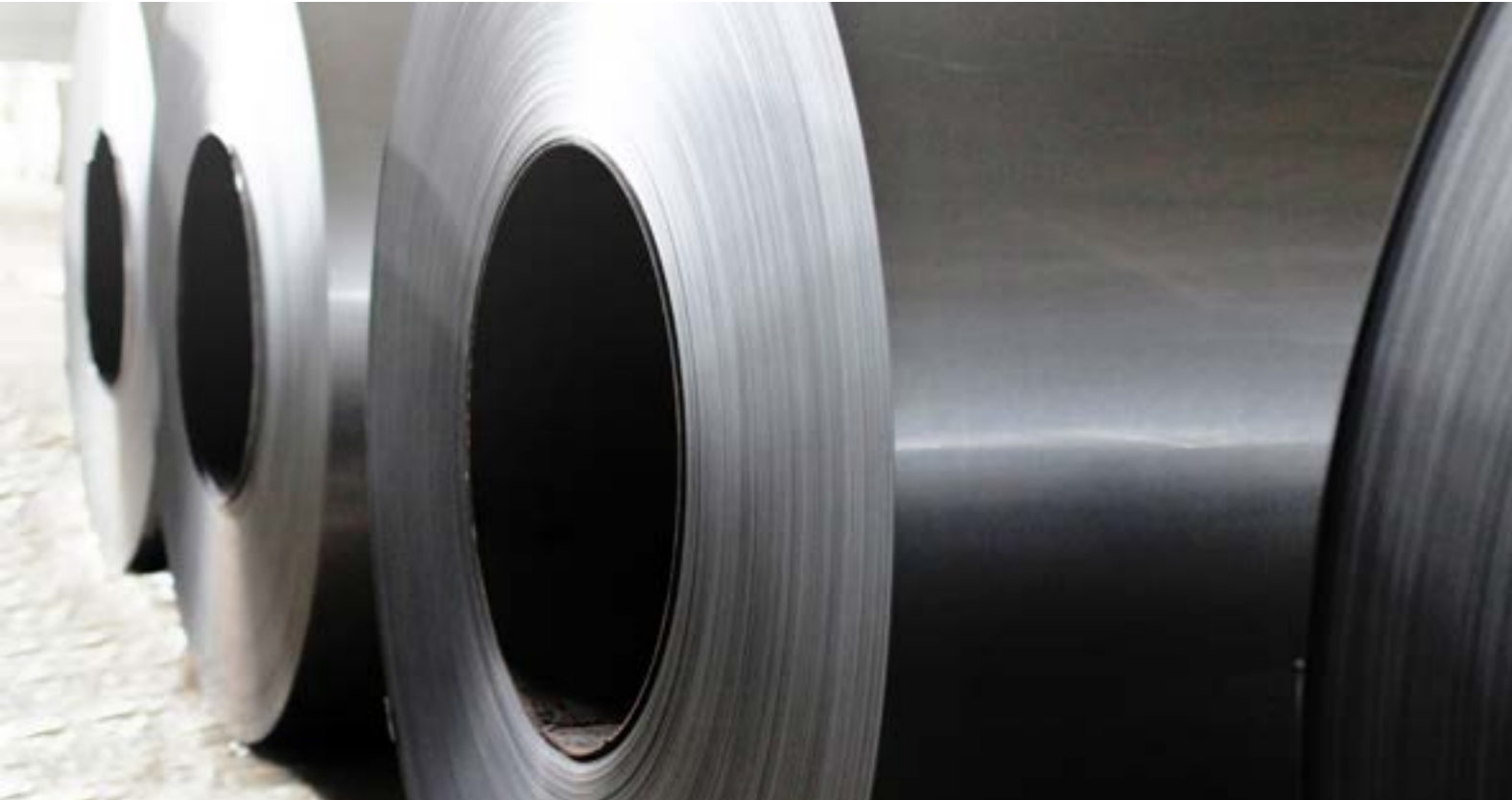

## Cold Rolled Coil



GRP also produces our coil products in cold rolled form to cater to specific materials requirement for that unique product application.

This flat steel product rolled into thinner sizes while it is in normal room temperature to the exact thickness requirement and rolled into coils. The resulting of cold rolled coils is that they have a better surface quality, thinner profiles, and excellent finishes, and can be made into different type of products by means of cold forming.

**Standard & Specification:**

JIS G 3141 spec 1B  
JIS G 3141 spec SB  
JIS G 3141 spec SD

**Available Size:**

Thickness 0.2mm – 2.5mm  
Width 700mm – 1270mm  
Maximum 27 MT/Coil

**Annual Capacity:**

500.000 MT/Year



## Cut To Shape



With multi head oxy flame cutting machines we can cut thick mild steel material up to 300 mm thick. Our large cutting facility 3500 mm wide X 25000 mm long , 6 ESAB Make CNC Oxy cutting machine coupled with multi head flame cutting facility, make flame cutting accurate and ideal for high production.

We have eight multi head oxy flame flat bar cutting facility of capacity 3000 mm wide and 20,000 long and one plasma cutting machine with the cutting capacity of 20 mm thick x 6000 mm long. In addition to oxy cutting we have two shearing machines of capacity 13 mm thick X 12000 mm long.

### Standard & Specification:

Thickness and flatness tolerance in accordance with standard. Profiling tolerance +/- 2 mm to +/- 6 mm depending on thickness and size (length & Width).

### Size Chart:

Cutting Thickness 3 mm to 300 mm, full range of mild and carbon steels readily available or met to order supply by our plate mill.

Width 3000 mm, Length 25000 mm

### Annual Capacity:

Average 12.000 Ton per Year (dependent on size of CTS and specification of material).



**ERW Pipe**  
(Electric Resistance Welded Pipe)

With many different application and uses that can be achieved from using round pipe products, at GRP we manufactured our pipe from 2 3/8" OD in a variety of length to over 100 feet using Electric Resistance Welding (ERW) methods.

As we strive to maintain to the highest standard quality, our ERW tubular pipe complied with different local and international standard specifications for its varying application requirements.

The surface finish for this product is available in bare or in coated form and the processing will be carried out in our facility. For the application carrying flow of water / liquid material, we can also perform hydrostatic testing on the products to ensure leakage-proof in its operations.

**Standard & Specification:**

ASTM A53 (A), BS 1387 : 1985 Heavy Series (H)	JIS G 3444 STK 400,
Medium Series (M)	JIS G 3445 STKM 11 A, STKM 12 A
Light Series (L)	JIS G 3452 SGP Black And Galvanized Pipe,
BS EN 10255 : 2004 (E)	JIS G 3454 STPG 370,
JIS G 3444 STK 290,	SNI 07 – 0068 – 2007 PKB 30,
	SNI 07 – 0068 2007 PKB 41

**Available Size:**

1 inch OD to 6 inch OD  
(Outside Diameter)  
Thickness 2mm-6mm

**Annual Capacity:**

70.000 MT/Year



**ASTM A 53 (A)**

Normal Size		Outside Diameter (mm)	Thickness (mm)	Sch	Test Pressure	
DN	NPS				Psi	Kg/cm <sup>2</sup>
25	1"	33,4	3,38	40	700	49
32	1 1/4"	42,2	3,56	40	1200	85
40	1 1/2"	48,3	3,68	40	1200	85
50	2"	60,3	3,91	40	2300	161
65	2 1/2"	73	5,16	40	2500	175
80	3"	88,9	3,18	-	1290	91
			3,96	-	1600	112
			4,78	-	1930	136
			5,49	40	2220	156
100	4"	114,3	3,18	-	1000	70
			3,96	-	1250	88
			4,78	-	1500	105
			5,56	-	1750	123
			6,02	40	1900	134

**Chemical composition**

Carbor (C)	: 0.25 % max
Posphor (p)	: 0.05 % max
Sulphur (s)	: 0.045 % max

**Mechanical properties**

Tensile Strength	: 330 N/mm <sup>2</sup> Min
Yield Strength	: 205 N/mm <sup>2</sup> Min
Elongation	: 22% min

**tolerance**

Thickness	: ± 12.5%
Outside Diamenter	
OD ≤ 48.3 mm	: ± 0.4 mm
OD ≥ 60.3 mm	: ± 1%

**BS 1387:1985**

Light (L)

Normal Size		Outside Diameter		Wall Thickness T (mm)	Hydrostatic Test	
DN (mm)	Thread Size R	Max (mm)	Min (mm)		Psi	BAR
25	1	33,8	33,2	2,6	730	50
32	1 1/4	42,5	41,9	2,6	730	50

**Chemical composition**

Carbor (C)	: 0.20 % max
Posphor (p)	: 0.045 % max
Sulphur (s)	: 0.045 % max

**Mechanical properties**

Tensile Strength	: 320 ~ 460 N/mm <sup>2</sup>
Yield Strength	: 195 N/mm <sup>2</sup> Min
Elongation	: 20% min

**Tolerance**

Thickness light tubes	: - 8%
Medium and heavy tubes	: - 10%

**BS 1387:1985**

Medium Series (M)

Normal Size		Outside Diameter		Wall Thickness T (mm)	Hydrostatic Test	
DN (mm)	Thread Size R	Max (mm)	Min (mm)		Psi	BAR
32	1 1/4	42,9	42,1	3,2	730	50
40	1 1/2	48,8	48	3,2	730	50
50	2	60,8	59,8	3,6	730	50
65	2 1/2	76,6	75,4	3,6	730	50
80	3	89,5	88,1	4,0	730	50
100	4	114,9	113,3	4,5	730	50
125	5	140,6	138,7	5,0	730	50
150	6	166,1	164,1	5,0	730	50

**BS 1387:1985**

Heavy (H)

Normal Size		Outside Diameter		Wall Thickness T (mm)	Hydrostatic Test	
DN (mm)	Thread Size R	Max (mm)	Min (mm)		Psi	BAR
65	2 1/2	76,6	75,4	4,5	730	50
80	3	89,5	88,1	5,0	730	50
100	4	114,9	113,3	5,4	730	50
125	5	140,6	138,7	5,4	730	50
150	6	166,1	164,1	5,4	730	50

BS EN 10255:2004 (E)

Type L

Nominal Size DN (mm)	Thread Size R	Specified Outside Diameter (mm)	Outside Diameter		Wall Thickness T (mm)	Hydrostatic Test	
			Max (mm)	Min (mm)		Psi	BAR
25	1	33.7	34.2	33.3	2.9	730	50
32	1 1/4	42.4	42.9	42	2.9	730	50
40	1 1/2	48.3	48.8	47.9	2.9	730	50
50	2	60.3	60.8	59.7	3.2	730	50
65	2 1/2	76.1	76.6	75.3	3.2	730	50
80	3	88.9	89.5	88	3.2	730	50
100	4	114.3	115	113.1	3.6	730	50
125	5	139.7	140.8	138.5	4.5	730	50
150	6	165.1	166.5	163.9	4.5	730	50

Type L2

Nominal Size DN (mm)	Thread Size R	Specified Outside Diameter (mm)	Outside Diameter		Wall Thickness T (mm)	Hydrostatic Test	
			Max (mm)	Min (mm)		Psi	BAR
25	1	33.7	34.2	33.3	2.6	730	50
32	1 1/4	42.4	42.9	42	2.6	730	50
40	1 1/2	48.3	48.8	47.9	2.9	730	50
50	2	60.3	60.8	59.7	2.9	5	50
65	2 1/2	76.1	76.6	75.3	3.2	730	50
80	3	88.9	89.5	88	3.2	730	50
100	4	114.3	115	113.1	3.6	730	50

Type LI

Nominal Size DN (mm)	Thread Size R	Specified Outside Diameter (mm)	Outside Diameter		Wall Thickness T (mm)	Hydrostatic Test	
			Max (mm)	Min (mm)		Psi	BAR
25	1	33.7	34.2	33.3	2.9	730	50
32	1 1/4	42.4	42.9	42	2.9	730	50
40	1 1/2	48.3	48.8	47.9	2.9	730	50
50	2	60.3	60.8	59.7	3.2	730	50
65	2 1/2	76.1	76.6	75.3	3.2	730	50
80	3	88.9	89.5	88	3.6	730	50
100	4	114.3	115	113.1	4.0	730	50

Heavy Series (H)

Nominal Size DN (mm)	Thread Size R	Specified Outside Diameter (mm)	Outside Diameter		Wall Thickness T (mm)	Hydrostatic Test	
			Max (mm)	Min (mm)		Psi	BAR
50	2	60.3	60.8	59.7	4.5	730	50
65	2 1/2	76.1	76.6	75.3	4.5	730	50
80	3	88.9	89.5	88	5.0	730	50
100	4	114.3	115	113.1	5.4	730	50
125	5	139.7	140.8	138.5	5.4	730	50
150	6	165.1	166.5	163.9	5.4	730	50

BS EN 10255:2004 (E)

Medium Series (M)

Nominal Size DN (mm)	Thread Size R	Specified Outside Diameter (mm)	Outside Diameter		Wall Thickness T (mm)	Hydrostatic Test	
			Max (mm)	Min (mm)		Psi	Bar
25	1	33.7	34.2	33.3	3.2	730	50
32	1 1/4	42.4	42.9	42	3.2	730	50
40	1 1/2	48.3	48.8	47.9	3.2	730	50
50	2	60.3	60.8	59.7	3.6	730	50
65	2 1/2	76.1	76.6	75.3	3.6	730	50
80	3	88.9	89.5	88	4.0	730	50
100	4	114.3	115	113.1	4.5	730	50
125	5	139.7	140.8	138.5	5.0	730	50
150	6	165.1	166.5	163.9	5.0	730	50

JIS G 3444 STK 290

Outside Diameter (mm)	Thickness (mm)	Cros Sectional Area cm <sup>2</sup>
34	2,3	2,291
42,7	2,3	2,919
	2,5	3,157
48,6	2,3	3,345
	2,5	3,621
	2,8	4,029
60,5	3,2	4,564
	2,3	4,205
	3,2	5,760
76,3	4,0	7,100
	2,8	6,495
	3,2	7,349
89,1	4,0	9,085
	2,8	7,591
	3,2	8,636
114,3	3,2	11,17
	3,5	12,18
	4,5	15,52
139,8	3,6	15,4
	4,0	17,07
	4,5	19,13
165,2	6,0	25,22
	4,5	22,72
	5,0	25,16
165,2	6,0	30,01
	7,1	35,26

Chemical composition

Posphor (p)	: 0.05 % max
Sulphur (s)	: 0.05 % max

Mechanical properties

Tensile Strength	: 290 N/mm <sup>2</sup> Min
Yield Strength	: -
Elongation	:
>1mm to 2mm	: 21%
>2mm to 3mm	: 22%
>3mm to 4mm	: 24%
>4mm to 5mm	: 26%
>5mm to 6mm	: 27%
>6mm to 7mm	: 28%

Tolerance

Thickness < 4 mm	: + 0.6%
	- 0.5 mm
4 mm to 12 mm	: + 15 %
	- 12.5 %
Length	: + Not specified
	- 0 mm
Outside Diameter	:
OD < 50 mm	: ± 0.5 mm
OD ≥ 50mm	: ± 1 %

NOTE : Non standard sizes are available upon request and subject to minimum quantity.



JIS G 3444 STK 400

Outside Diameter (mm)	Thickness (mm)	Cros Sectional Area cm <sup>2</sup>
48,6	2,3	3,345
	2,5	3,621
	2,8	4,029
60,5	2,3	4,205
	3,2	5,760
76,3	2,8	6,495
	3,2	7,349
89,1	2,8	7,591
	3,2	8,636
114,3	3,2	11,17
	3,5	12,18
	4,5	15,52
139,8	3,6	15,4
	4,0	17,07
	4,5	19,13
165,2	4,5	22,72
	5,0	25,16
	6,0	30,01

NOTE : Non standard sizes are available upon request and subject to minimum quantity.

SNI 07-0068-1987 PKB 30

Nominal Size		Outside Diameter (mm)	Thickness (mm)	Cross Sectional Area cm <sup>2</sup>
A	B			
25	1"	34	2.3	2.291
32	1 1/4"	42.7	2.3	2.919
			2.8	3.157
			2.3	3.345
40	1 1/2"	48.6	2.8	4.029
			3.2	4.564
			2.3	4.205
			3.2	5.760
50	2"	60.5	4.0	7.100
			2.8	6.465
			3.2	7.439
65	2 1/2"	76.3	4.0	9.085
			2.8	7.591
80	3"	89.1	3.2	8.936
			4.0	10.690
			3.2	11.170
100	4"	114.3	3.6	12.520
			4.5	15.520
			3.6	15.400
125	5"	139.8	4.0	17.070
			4.5	19.130
			6.0	25.220
			4.5	22.720
150	6"	165.2	5.0	25.160
			6.0	30.010
			7.0	34.790

NOTE : Non standard sizes are available upon request and subject to minimum quantity.

Chemical composition

Carbor (C) : 0.25 % max  
 Posphor (p) : 0.04 % max  
 Sulphur (s) : 0.04 % max

Mechanical properties

Tensile Strength : 400 N/mm<sup>2</sup> Min  
 Yield Strength : 235 N/mm<sup>2</sup> Min  
 Elongation :  
 >1mm to 2mm : 14%  
 >2mm to 3mm : 16%  
 >3mm to 4mm : 17%  
 >4mm to 5mm : 18%  
 >5mm to 6mm : 20%  
 >6mm to 7mm : 22%

Tolerance

Thickness <4mm : + 0,6 mm  
 - 0,5 mm  
 4 mm to 12 mm : + 15 %  
 - 12,5 %  
 Length : + 50 mm  
 - 0 mm  
 Outside Diameter  
 OD < 50 mm : + Not specified ± 0,5 mm  
 OD ≥ 50mm : ± 1 %

Chemical Composition

• Phosphor (p) : 0.05 % max  
 • Sulfur (s) : 0.05 % max

Mechanical Properties

• Tensile Strength : 294 N/mm<sup>2</sup> min  
 • Yield Strenth : -  
 • Elongation : 21 % min

Tolerance

• Thickness < 3 mm : ± 0.3mm  
 3 mm s/d 12 mm : ± 10 %  
 • Length : ± 2 %  
 • Outside Diameter  
 OD ≤ 50 mm : ± 0.5 mm  
 OD ≥ 50 mm : ± 1 %  
 Standard length of pipe : 6000 mm

SNI 07-0039-1987 (Medium)

Galvanized Pipe

Nominal Size		Outside Diameter (mm)	Thickness (mm)	Cross Sectional Area cm <sup>2</sup>
A	B			
32	1 1/4"	42.7	2.8	3.510
40	1 1/2"	48.6	2.8	4.029
			3.2	4.564
50	2"	60.5	2.3	4.205
			3.2	5.760
65	2 1/2"	76.3	2.8	6.465
			3.2	7.349
80	3"	89.1	2.8	7.591
			3.2	8.936
100	4"	114.3	3.2	11.170
			3.6	12.520
			3.6	15.400
125	5"	139.8	4.0	17.070
			4.5	19.130
			6.0	23.600
			4.5	22.720
150	6"	165.2	5.0	25.160
			6.0	30.010
			7.0	34.790

Chemical Composition

• Carbon (C) : 0.25 % max  
 • Phosphor (p) : 0.04 % max  
 • Sulfur (s) : 0.04 % max

Mechanical Properties

• Tensile Strength : 402 N/mm<sup>2</sup> min  
 • Yield Strenth : 235 N/mm<sup>2</sup> min  
 • Elongation : 14 % min

Tolerance

• Thickness < 3 mm : ± 0.3mm  
 3 mm s/d 12 mm : ± 10 %  
 • Length : ± 2 %  
 • Outside Diameter  
 OD ≤ 50 mm : ± 0.5 mm  
 OD ≥ 50 mm : ± 1 %  
 Standard length of pipe : 6000 mm

SNI - 07 - 0039 - 1987 (Medium)

Galvanized Pipe

Nominal Size		Outside Diameter (mm)		Thickness (mm)	Test Pressure	
A	B	Max	Min		Psi	Kgf/cm <sup>2</sup>
25	1"	34.2	33.4	3.25	710	50
32	1 1/4"	42.9	42.1	3.25	710	50
40	1 1/2"	48.80	48.0	3.25	710	50
50	2"	60.8	59.8	3.65	710	50
65	2 1/2"	76.6	75.4	3.65	710	50
80	3"	89.5	88.1	4.05	710	50
100	4"	114.9	113.3	4.5	710	50
125	5"	140.6	138.7	4.85	710	50
250	6"	166.1	164.1	4.9	710	50

Chemical Composition

• Phosphor (p) : 0.05 % max  
 • Sulfur (s) : 0.05 % max

Mechanical Properties

• Tensile Strength : 33 Kgf/mm<sup>2</sup> min  
 • Elongation : 20 % min

Tolerance

• Thickness : + Unlimited  
 - 10%  
 • Length : ± 2 %  
 • Weight with zinc : 300 gr/m<sup>2</sup>  
 Standard length of pipe : 6000 mm

JIS G3452 SGP

Black Galvanized Pipe

Normal Size		Outside Diameter (mm)	Thickness (mm)	Test Pressure	
A	B			Psi	Kgf/cm <sup>2</sup>
25	1"	34	3,2	365	25
32	1 1/4"	42,7	3,5	365	25
40	1 1/2"	48,6	3,5	365	25
50	2"	60,5	3,8	365	25
65	2 1/2"	76,3	4,2	365	25
80	3"	89,1	4,2	365	25
100	4"	114,3	4,5	365	25
125	5"	139,8	4,5	365	25
150	6"	165,2	5,0	365	25

NOTE : Non standard sizes are available upon request and subject to minimum quantity.

Chemical composition

Phosphor (p) : 0.04 % max  
 Sulphur (s) : 0.04 % max

Mechanical properties

Tensile Strength : 290 N/mm<sup>2</sup> Min  
 Elongation :  
 Over 3mm up to and incl 4mm : 24%  
 Over 3mm up to and incl 4mm : 26%

Tolerance

Thickness : + Not specified  
 - 12.5%  
 Outside Diamenter :  
 OD < 50 mm : ± 0.5 mm  
 OD ≥ 50mm : ± 1 %  
 Weight with Zinc 400 gr/m<sup>2</sup>

JIS G 3445

Carbon Steel Tube For Machine Structural Purposes

Outside Diameter (mm)	STKM 11 A	STKM 13 A	STKM 14 A
	Tch (mm)	Tch (mm)	Tch (mm)
33,4	2 sd 3.2	2 sd 3.2	2 sd 2.2
42,2	2 sd 3.4	2 sd 3.4	2 sd 2.5
48,3	2 sd 3.6	2 sd 3.6	2 sd 2.8
60,3	2 sd 4.0	2 sd 4.0	2 sd 3.2
73	2 sd 4.85	2 sd 4.85	2 sd 3.4
76	2 sd 4.85	2 sd 4.85	2 sd 3.4
88,9	2 sd 5.2	2 sd 5.2	2 sd 3.6
114,3	2.5 sd 5.8	2.5 sd 5.8	2.5 sd 4.5
139,8	3.6 sd 6.5	3.6 sd 6.5	3.6 sd 6.0
165,2	3.6 sd 7.0	3.6 sd 7.0	3.6 sd 6.5

Note: Non standard sizes are available upon request and subject to minimum quantity.

Grade	Designation	Chemical composition %					Mechanical Property						
		C Max	Si Max	Mn Max	P Max	S Max	Tensile test				Flatting test (D:Outside diameter)	Bending test	
							Ts Min	Ys Min	El Min (%)			Bending angle	Inside radius
									N/mm <sup>2</sup>	N/mm <sup>2</sup>			
Grade 11	A STKM 11 A	0,12	0,35	0,6	0,04	0,04	290	-	35	30	½ D	180°	4 D
Grade 13	A STKM 13 A	0,25	0,35	0.3 to 0.9	0,04	0,04	370	215	30	25	¾ D	90°	6 D
Grade 14	A STKM 14 A	0,3	0,35	0.3 to 1.0	0,04	0,04	410	245	25	20	¾ D	90°	6 D

Elongation of tubes with a wall thickness under 8mm

Grade	Symbol of grade	Test piece	Wall Thickness						
			>1mm to 2mm	>2mm to 3mm	>3mm to 4mm	>4mm to 5mm	>5mm to 6mm	>6mm to 7mm	
Grade 11	A	STKM 11 A	Test piece no.5	21 Min	22 Min	24 Min	26 Min	27 Min	28 Min
			Test piece no.12	26 Min	28 Min	29 Min	30 Min	32 Min	34 Min
Grade 13	A	STKM 13 A	Test piece no.5	16 Min	18 Min	19 Min	20 Min	22 Min	24 Min
			Test piece no.12	21 Min	22 Min	24 Min	26 Min	27 Min	28 Min
Grade 14	A	STKM 14 A	Test piece no.5	11 Min	12 Min	14 Min	16 Min	17 Min	18 Min
			Test piece no.12	16 Min	18 Min	19 Min	20 Min	22 Min	24 Min

Standar Tolerances

Division	Tolerances on outside diameter	Division	Tolerances on wall thickness
1	Under 50 mm	1	Under 4 mm
	50 mm or ofer		+ 0.6 mm
2	Under 50 mm	2	4 mm or over
	50 mm or ofer		+ 15 %
3	Under 25mm	3	Under 3 mm
	25 mm or over to and exd. 40mm		+ 12.5 %
	40 mm or over to and exd. 50 mm		± 0.18 mm
	50 mm or over to and exd. 60 mm		± 0.2 mm
	60 mm or over to and exd. 70 mm		± 0.23 mm
	70 mm or over to and exd. 80 mm		± 0.25 mm
	80 mm or over to and exd. 90 mm		± 0.3 mm
	90 mm or over to and exd. 100 mm		± 0.4 mm
	100 mm or over		± 0.5 %
	Tolerances		+50
		-0	

\* If there are no found special agreement between the order and manufacturer while processing the order, Then for the tolerance outside the diameter will be applied the rule no. 1, and the tolerance of wall thickness would be the rule no. 2.

SNI 0039 2013

Galvanized Pipe & Black Pipe ( Tipis )

Diameter dalam Normal		Diameter luar (mm)			Thickness (mm)	Test Pressure	
(mm)	(inci)	Normal	Max	Min		Psi	Kgf/cm <sup>2</sup>
25	1"	33,6	34	33,2	2,6	710	50
32	1 1/4"	42,3	42,7	41,9	2,6	710	50
40	1 1/2"	48,20	48,60	47,8	2,9	710	50
50	2"	60,2	60,8	59,6	2,9	710	50
65	2 1/2"	76	76,7	75,2	3,2	710	50
80	3"	88,8	89,7	87,9	3,2	710	50
100	4"	114,1	115,3	113	3,6	710	50
125	5"	139,7	140,5	137,7	3,6	710	50
150	6"	165,1	166,8	163,4	3,6	710	50

Chemical Composition

Carbon (C)	: 0.2 % max
Mangan (Mn)	: 1.4 % max
Posphor (p)	: 0.035 % max
Belerang (s)	: 0.03 % max

Mechanical properties

Tensile Strength	: 33 sd 47 kgf/mm <sup>2</sup>
Yield Strength	: 20 kgf/mm <sup>2</sup> min
Elongation	: 20% min

Tolerance

Pipe Standard Length	: 6000 mm
	: 12000 mm
Length 6 m	: + 100
Length 12 m	: + 100
	: - 0
Weight with Zinc 300 gr/m <sup>2</sup>	: - 0

SNI 0039 2013

Galvanized Pipe & Black Pipe ( Medium )

Diameter dalam Normal		Diameter luar (mm)			Thickness (mm)	Test Pressure	
(mm)	(inci)	Normal	Max	Min		Psi	Kgf/cm <sup>2</sup>
25	1"	33,7	34,2	33,3	3,2	710	50
32	1 1/4"	42,4	42,9	42	3,2	710	50
40	1 1/2"	48,30	48,80	47,9	3,2	710	50
50	2"	60,3	60,8	59,7	3,6	710	50
65	2 1/2"	76,1	76,6	75,3	3,6	710	50
80	3"	88,9	89,5	88	4	710	50
100	4"	114,3	115	113,1	4,5	710	50
125	5"	139,7	140,8	138,5	5	710	50
150	6"	165,1	166,5	163,9	5	710	50

Pipa Tipis

• Tebal	: + 10%
	: - 8%

Pipa Medium

• Tebal	: + 15%
	: - 10%

Pipa Medium

• Tebal	: + 15%
	: - 12.5%

SNI 0039 2013

Galvanized Pipe & Black Pipe ( Tebal )

Diameter dalam Normal		Diameter luar (mm)			Thickness (mm)	Test Pressure	
(mm)	(inci)	Normal	Max	Min		Psi	Kgf/cm <sup>2</sup>
65	2 1/2"	76	76,6	75,4	4,5	710	50
80	3"	88,8	89,5	88,1	5	710	50
100	4"	114,1	114,9	113,3	6,0	710	50
125	5"	139,7	142,7	138,7	6,6	710	50

**SNI 0068 : 2013 PKB ( STK ) - 290**

Outside Diameter (mm)	Thickness (mm)	Cros Sectional Area cm <sup>2</sup>
34	2,3	2,291
42,7	2,3	2,919
	2,5	3,157
48,6	2,3	3,345
	2,8	4,029
60,5	3,2	4,564
	2,3	4,205
76,3	3,2	5,760
	4,0	7,100
89,1	2,8	6,465
	3,2	7,349
114,3	4,0	9,085
	2,8	7,591
139,8	3,2	8,636
	4,0	10,690
165,2	3,2	11,170
	3,6	12,520
187,5	4,5	15,520
	5,6	19,120
219,1	3,6	15,400
	4,0	17,070
244,8	4,5	19,130
	6,0	25,220
273,0	4,5	22,720
	5,0	25,160
304,8	6,0	30,010
	7,0	34,790

**Chemical Composition**

Posphor (p)	: 0.05 % max
Belering (s)	: 0.05 % max

**Mechanical properties**

Tensile Strength	: 294 n/mm <sup>2</sup> Min
Yield Strength	: -
Elongation	: 30 % Min

Uji tarik untuk pipa dengan tebal kurang dari 8mm di lakukan dengan batang uji No.12 atau No.5, nilai minimum elongasi dapat di hitung dengan mengurangi elongasi tersebut dengan laju pengurangan 1.5% per 1mm

**Tolerance**

Thickness < 4 mm	: ± 0.6 mm - 0.5 mm
4 mm s/d 12 mm	: + 15 % - 12.5 %
Length	: + 50 mm - 0 mm
Outside Diamentor	:
OD < 50 mm	: ± 0.5 mm
OD ≥ 50mm	: ± 1 %

Panjang Standard Pipa = 6000 mm dan 12000 mm

**SNI 0068 : 2013 PKB ( STK ) - 400**

Outside Diameter (mm)	Thickness (mm)	Cros Sectional Area cm <sup>2</sup>
48,6	2,3	3,345
60,5	2,8	4,029
	2,3	4,205
76,3	3,2	5,760
	2,8	6,465
89,1	3,2	7,349
	2,8	7,591
114,3	3,2	8,636
	3,2	11,170
139,8	3,6	12,520
	4,5	15,520
165,2	3,6	15,400
	4,0	17,070
187,5	4,5	19,130
	4,5	22,720
219,1	5,0	25,160
	6,0	30,010

**Chemical Composition**

Posphor (p)	: 0.05 % max
Belering (s)	: 0.05 % max

**Mechanical properties**

Tensile Strength	: 294 n/mm <sup>2</sup> Min
Yield Strength	: -
Elongation	: 30 % Min

Uji tarik untuk pipa dengan tebal kurang dari 8mm di lakukan dengan batang uji No.12 atau No.5, nilai minimum elongasi dapat di hitung dengan mengurangi elongasi tersebut dengan laju pengurangan 1.5% per 1mm

**Tolerance**

Thickness < 4 mm	: ± 0.6 mm - 0.5 mm
4 mm s/d 12 mm	: + 15 % - 12.5 %
Length	: + 50 mm - 0 mm
Outside Diamentor	:
OD < 50 mm	: ± 0.5 mm
OD ≥ 50mm	: ± 1 %

Panjang Standard Pipa = 6000 mm dan 12000 mm



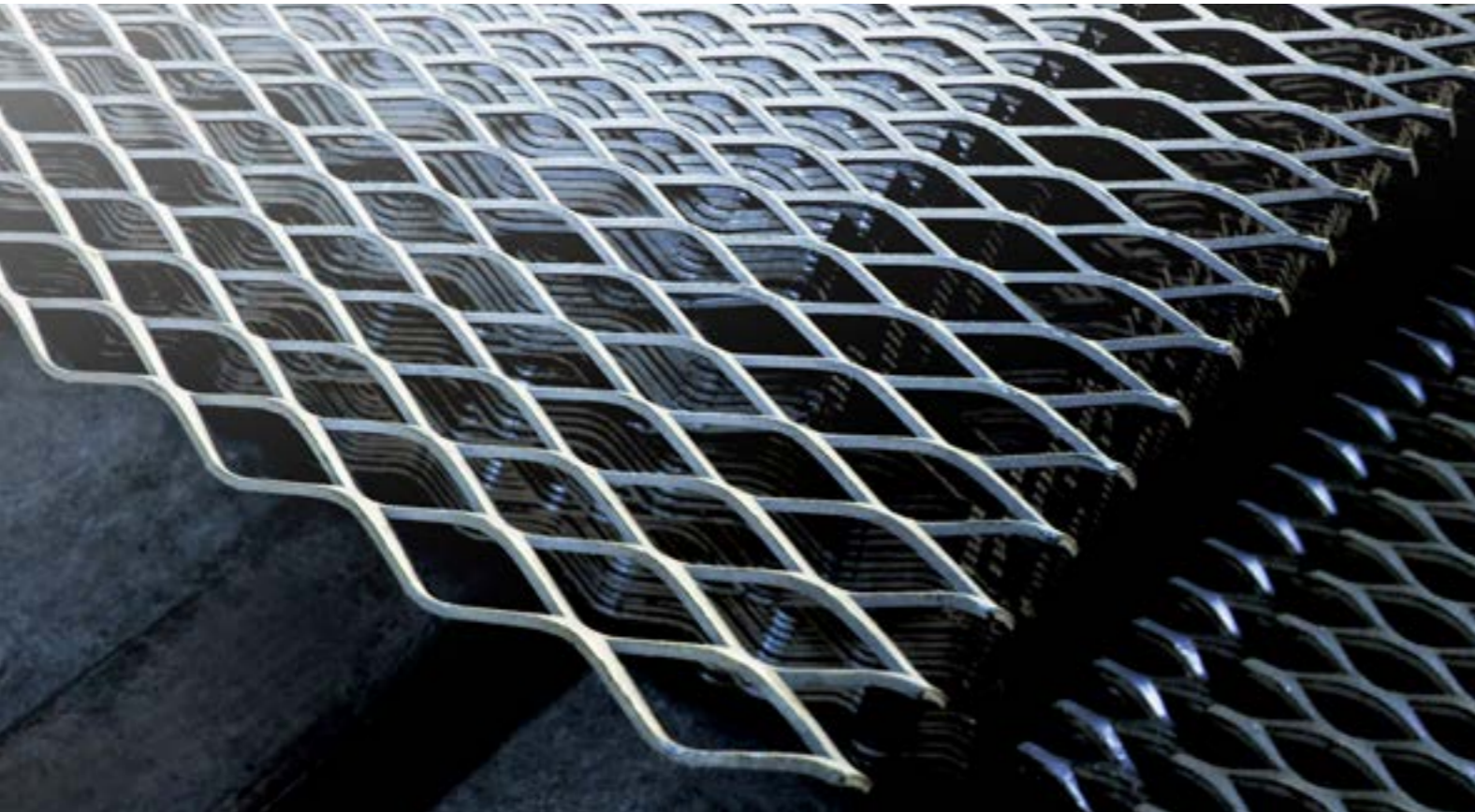

## Expanded Mesh



Expanded mesh is one continuous single sheet of mesh produced when a flat metal plate is sheared and stretched but is left intact at the 'knuckles'. It is available in a variety of thicknesses with differing sizes and designs of the apertures.

A further feature is the provision of an excellent anti-slip surface. This makes the product suitable for ramps (e.g. inclined walkways adjacent to conveyors) platforms and stair treads. The open nature of the product provides good visibility through the mesh as well as the easy passage of air and sound whilst ensuring security and protection.

<b>Standard &amp; Specification:</b>	<b>Available Size:</b>	<b>Annual Capacity:</b>
JIS G 3351	22 x 57 mm up to	3.000 MT/Year
JIS G 3131	75 x 200 mm	
ASTM 830	Thickness 4.85mm	

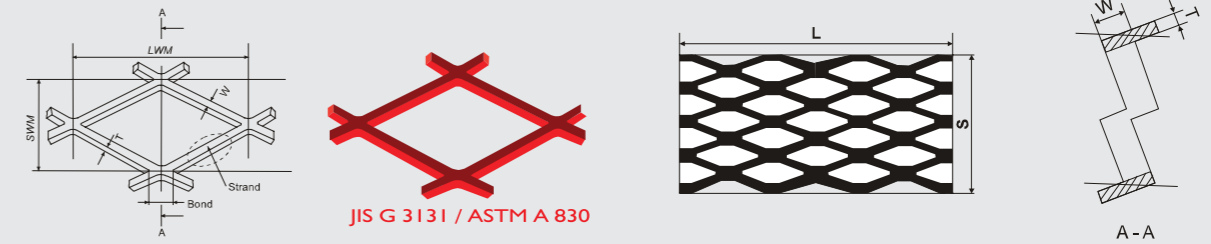

Type		Dimension		Mesh Size		Prod. Size	
		SWM (mm)	LWM (mm)	T (mm)	Width (mm)	L (mm)	P (S) (mm)
Expanded Ornamech	EOM 3035	22	57	3,0	3,5	1200	2400
	EOM 3045	35	76	3,0	4,5	1200	2400
Expanded Grid Mesh	EGM 30080	30	75	3,0	8,0	1200	2400
	EGM 50075	25	75	5,0	7,5	1200	2400
	EGM 50105	30	75	5,0	10,5	1200	2400
	EGM 50080	42	135	5,0	8,0	1200	2400
	EGM 50110	45	135	5,0	11,0	1200	2400
Expanded Merapi Mesh	EMM 50050	75	200	5,0	5,0	1200	2400
	EMM 30050	75	200	3,0	5,0	1200	2400
Expanded Merapi Mesh	EDM 30032	25	80	3,0	3,2	1200	2400

Material : JIS G 3131/ASTMA 830  
 Grade : SPHC/SAE 1006/1008  
 Tolerance : According to JIS G 3351

Tolerance on SW +/- 5%  
 Tolerance on LW +/- 2 mm  
 Tolerance on S + 25 mm, - 0 mm

Tolerance on L Value Given in JIS on Steel Sheet and Plate  
 Tolerance on T Value Given in JIS on Steel Sheet and Plate  
 Tolerance on Weight +/- 10 %  
 Deflection 5 mm or less per 1000 mm and not more than 5 mm x (length mm/1000 mm) for overall length





**Lipped Channel**

Lipped Channel is the ultimate alternative instead of Hot / Cold Rolled channel which has the same advantages such as reduced thickness and cost-effectiveness. Lipped Channels are often used for steel structures, storage areas, pollution control devices, and a variety of other architectural needs.

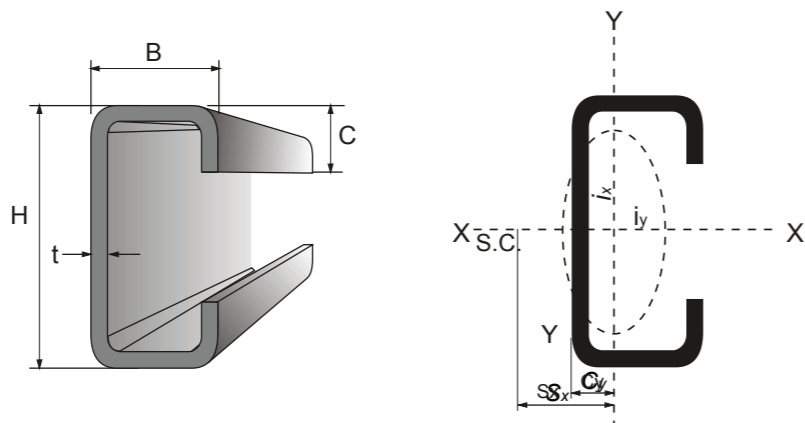

**Standard Material:**  
JIS G 3131 SPHC ,  
SAE 1006 / SAE 1008

**Std Dimensional Tolerances:**  
JIS G 3350

**Available Size:**  
CNP 100 x 50 x 2.0 mm up  
to CNP 200 x 75 x 3.2 mm

**Annual Capacity:**  
35.000 MT/Year

JIS G 3131 / ASTM 830

Metric Size

Dimension		Section Area	Unit Weight	Informative Reference									
				Geometrical Moment of Inertia		Modulus of Section		Modulus of Gyration		Center of Gravity	Shear Center	Torsion Constant	Warping Constant
H x B x C mm	t mm	A cm <sup>2</sup>	Kg /m	Ix cm <sup>4</sup>	Iy cm <sup>4</sup>	Zx cm <sup>3</sup>	Zy cm <sup>3</sup>	rx cm	ry cm	Cy cm	Xo cm	J cm <sup>4</sup>	Cw cm <sup>6</sup>
C 100 x 50 x 20	2	4.54	3.56	71	17	14.3	5.4	3.97	1.93	1.87	4.48	605	444
	2.3	5.17	4.06	81	19	16.1	6	3.95	1.92	1.86	4.46	912	496
	2.5	5.59	4.39	87	20	17.3	6.5	3.94	1.9	1.86	4.45	1164	528
	2.8	6.2	4.87	95	22	19.1	7.1	3.92	1.89	1.86	4.42	1621	574
	3	6.61	5.19	101	23	20.2	7.4	3.91	1.88	1.86	4.41	1982	603
C 125 x 50 x 20	3.2	7.01	5.5	106	24	21.3	7.8	3.9	1.87	1.86	4.4	2392	630
	2	5.04	3.95	120	18	19.3	5.5	4.89	1.91	1.69	4.15	672	675
	2.3	5.75	4.51	136	21	21.8	6.2	4.87	1.89	1.69	4.12	1013	755
	2.5	6.21	4.88	147	22	23.5	6.6	4.86	1.88	1.69	4.11	1295	805
	2.8	6.9	5.42	162	24	25.9	7.2	4.84	1.86	1.69	4.08	1804	877
C 150 x 50 x 20	3	7.36	5.78	172	25	27.5	7.6	4.83	1.85	1.69	4.07	2207	922
	3.2	7.81	6.13	181	27	29	8	4.82	1.84	1.68	4.05	2665	965
	2	5.54	4.35	185	19	24.7	5.6	5.79	1.87	1.55	3.86	738	971
	2.3	6.32	4.96	210	22	28	6.3	5.77	1.86	1.55	3.84	1115	1088
	2.5	6.84	5.37	226	23	30.2	6.8	5.75	1.85	1.55	3.82	1425	1162
C 150 x 65 x 20	2.8	7.6	5.97	250	26	33.3	7.4	5.73	1.83	1.54	3.8	1987	1267
	3	8.11	6.37	265	27	35.4	7.8	5.72	1.82	1.54	3.78	2432	1334
	3.2	8.61	6.76	280	28	37.4	8.2	5.71	1.81	1.54	3.77	2938	1398
	2	6.14	4.82	218	36	29.1	8.3	5.96	2.43	2.12	5.19	818	1784
	2.3	7.01	5.5	248	41	33	9.4	5.94	2.42	2.12	5.16	1236	2006
C 200 x 75 x 20	2.5	7.59	5.96	267	44	35.6	10	5.93	2.41	2.12	5.15	1581	2148
	2.8	8.44	6.63	295	48	39.4	11	5.91	2.39	2.12	5.13	2207	2352
	3	9.01	7.07	314	51	41.8	11.6	5.9	2.38	2.11	5.11	2702	2482
	3.2	9.57	7.51	332	54	44.2	12.2	5.89	2.37	2.11	5.09	3265	2608
	2	7.54	5.92	467	56	46.7	10.6	7.87	2.73	2.2	5.49	1005	4571
C 200 x 75 x 20	2.3	8.62	6.77	531	64	53.1	12	7.85	2.72	2.2	5.47	1520	5159
	2.5	9.34	7.33	573	68	57.3	12.9	7.84	2.71	2.2	5.45	1946	5537
	2.8	10.4	8.17	636	75	63.6	14.2	7.82	2.69	2.2	5.42	2719	6085
	3	11.11	8.72	676	80	67.6	15	7.8	2.68	2.19	5.41	3332	6437
	3.2	11.81	9.27	716	84	71.6	15.8	7.79	2.67	2.19	5.39	4030	6779

Technical Specification Material : JIS G 3131 / ASTM 830, Symbol : SPHC/ SAE 1006/ SAE 1008  
Standard length : 6 Meters, Dimention Tolerance : JIS G 3350

Note: Non standard sizes are available upon request and subject to minimum quantity

SNI 07-0138-1987

Dimension		Section Area	Unit Weight	Informative Reference									
				Geometrical Moment of Inertia		Modulus of Section		Modulus of Gyration		Center of Gravity	Shear Center	Torsion Constant	Warping Constant
H x B x C mm	t mm	A cm <sup>2</sup>	Kg /m	Ix cm <sup>4</sup>	Iy cm <sup>4</sup>	Zx cm <sup>3</sup>	Zy cm <sup>3</sup>	rx cm	ry cm	Cy cm	Xo cm	J cm <sup>4</sup>	Cw cm <sup>6</sup>
C 100 x 50 x 20	2.0	4.437	3.56	71	17	14.3	5.4	3.97	1.93	1.87	4.48	605	444
	2.3	5.172	4.06	81	19	16.1	6.0	3.95	1.92	1.86	4.46	912	496
	2.8	6.205	4.87	95	22	19.1	7.1	3.92	1.89	1.86	4.42	1621	574
C 125 x 50 x 20	3.2	7.007	5.50	106	24	21.3	7.8	3.90	1.87	1.86	4.40	2392	630
	2.3	5.747	4.51	136	21	21.8	6.2	4.87	1.89	1.69	4.12	1013	755
	3.2	7.807	6.13	181	27	29.0	8.0	4.82	1.84	1.68	4.05	2665	965
C 150 x 50 x 20	2.3	6.32	4.96	210	22	28.0	6.3	5.77	1.86	1.55	3.84	1115	1088
	3.2	8.607	6.76	280	28	37.4	8.2	5.71	1.81	1.54	3.77	2938	1398
C 150 x 65 x 20	2.3	7.01	5.50	248	41	33.0	9.4	5.94	2.42	2.12	5.16	1236	2006
	3.2	9.57	7.51	332	54	44.2	12.2	5.89	2.37	2.11	5.09	3265	2608
C 200 x 75 x 20	3.2	11.81	9.27	716	84	71.6	15.8	7.79	2.67	2.19	5.39	4030	6779

Chemical Composition		Mechanical Properties		Tolerance	
• Carbon (C)	: 0.25 % max	• Tensile Strength	: 176.4 N/mm <sup>2</sup> min	• Thickness ≤ 2.3 mm	: ± 0.24 mm
• Phosphor (p)	: 0.05 % max	• Yield Strenth	: 333.2 N/mm <sup>2</sup> min	≤ 3.2 mm	: ± 0.3 mm
• Sulfur (s)	: 0.05 % max	• Elongation	: 21 % min	• High (H) ≤ 125 mm	: ± 1.5 mm
				≤ 250 mm	: ± 2.0 mm
				• Width (B) ≤ 75 mm	: ± 2.0 mm
				• Lip (C) ≤ 25 mm	: ± 2.0 mm
				• Length 6 - 7 M	: ± 40 mm



# Spiral Pipe

The versatile spiral-welded steel pipes are popular among different applications in the oil & gas industries, building construction and water / liquid distribution system. This type of pipe product is often used for foundation piling, liquid flow distribution system and ports / jetty construction.

**Available Size:**

OD (Outside Diameter)  
165mm–3200mm  
Length 6000–45000 mm

**Annual Capacity:**

89.400 MT/Year

**Standard & Specifications:**

GRP produces our pipe with the automatic double-sided Submerged Arc Welding (S.A.W) technology to ensure the great consistency of our welding and the quality of our final product.

For a specific work project, we are able produce the spiral-welded steel pipes to suit different thickness and the diameter of up to 126” OD. In addition, we are able to provide additional coating services with different type of material to the pipe depending on the project’s requirement.

Standard	Main Application	Grade
API 5L	High strength oil & gas pipelines, slurry lines, refinery piping, etc.  notes: EW : electric welded CW : continuous welded NE : non expanded CE : cold expanded	A 25 CI I EW/CW
		A25 CI II EW/CW
		A NE/CE
		B NE/CE
		X 42 NE/CE
		X 46 NE
		X 52 NE
		X 56 NE/CE
		X 60 NE/CE
		X 65 NE/CE
X 70 NE/CE		
X 80 NE/CE		

Standard	Main Application	Grade
ASTM A 252	Piping	1
		2
		3
AWWA C 200	Water & sewage systems. Optionally pipes maybe supplied according to ASTM A 53, A 135	ASTM A 36
		ASTM A 283
		C
		D
		30
		33
		36
		40
		45
		50
ASTM A 572		42
		50
		50
		60

Standard	Main Application	Grade
DIN 1626	General Application	USt 37 - 1
		RSt 37 - 1
		USt 37 - 2
		RSt 37 - 2
		St 37 - 3
		USt 42 - 1
		RSt 42 - 1
		USt 42 - 2
		RSt 42 - 2
		St 52 - 3
BS 3601	General Application	320
		360
		430

Outside Diameter	Thickness																		
	inch	mm	6	8	9	10	11	12	12.7	13	14	15	16	17	18	19	20	21	22
8	203.2	29.18	38.51	43.10	47.64	52.14	56.58	59.66	60.97	65.32	69.62	73.86	78.06	82.21	86.31	90.35	-	-	-
10	254	36.69	48.53	54.38	60.17	65.92	71.61	75.57	77.26	82.86	88.41	93.91	99.36	104.21	110.11	115.41	-	-	-
12	304.8	44.21	58.55	65.65	72.70	79.70	86.61	91.48	93.55	100.40	107.2	113.95	120.65	127.30	133.91	140.46	-	-	-
14	355.6	51.73	68.57	76.92	85.22	93.48	101.68	107.39	109.83	117.93	125.99	133.99	141.95	149.85	157.71	165.52	-	-	-
16	406.4	59.24	78.60	88.20	97.75	107.26	116.71	123.30	126.12	135.47	144.78	154.04	163.24	172.40	181.51	190.57	-	-	-
18	457.2	66.76	88.62	99.47	110.28	121.04	131.74	139.21	142.40	153.01	163.57	174.08	184.54	194.95	205.31	215.63	-	-	-
20	508	74.28	98.64	110.75	122.81	134.82	146.78	155.12	158.69	170.55	182.36	194.12	205.84	217.50	229.12	240.68	-	-	-
22	558.8	81.79	108.66	122.02	135.33	148.60	161.81	171.03	174.97	188.09	201.15	214.17	227.13	240.05	252.92	265.74	-	-	-
24	609.6	89.31	118.68	133.30	147.86	162.38	176.84	186.94	191.26	205.62	219.94	234.21	248.43	262.60	276.72	290.79	-	-	-
26	660.4	96.83	128.71	144.57	160.39	176.16	191.87	202.85	207.54	223.16	238.73	254.25	269.73	285.15	300.52	315.85	-	-	-
28	711.2	104.34	138.73	155.85	172.92	189.94	206.91	218.76	223.83	240.70	257.52	274.30	291.02	307.70	324.32	340.90	-	-	-
30	762	111.86	148.75	167.12	185.44	203.72	221.94	234.67	240.11	258.24	276.32	294.34	312.32	330.25	348.13	365.95	-	-	-
32	812.8	119.37	158.77	178.40	197.97	217.50	236.97	250.58	256.40	275.78	295.11	314.39	333.62	352.80	371.93	391.01	-	-	-
34	863.6	126.89	168.79	189.67	210.50	231.28	252.01	266.49	272.69	293.32	313.90	334.43	354.91	375.34	395.73	416.06	-	-	-
36	914.4	134.41	178.81	200.94	223.03	245.06	267.04	282.40	288.97	310.85	332.69	354.44	376.21	397.89	419.53	441.12	-	-	-
38	965.2	141.92	188.84	212.22	235.55	258.84	282.07	298.31	305.26	328.38	351.48	374.52	397.50	420.44	443.33	466.17	-	-	-

Weight/M (Kg/M) = (OD-T)xTx0.2466  
OD = Outside Diameter (mm)  
T = Thickness (mm)

Outside Diameter	Thickness																		
	inch	mm	6	8	9	10	11	12	12.7	13	14	15	16	17	18	19	20	21	22
40	1011.6	149.44	198.86	223.49	248.08	272.62	297.10	314.22	321.54	345.93	370.27	394.56	418.80	442.99	467.13	491.23	-	-	-
42	1066.8	156.96	208.88	234.77	260.61	286.40	312.15	330.13	337.83	363.47	389.06	414.60	440.80	465.54	490.94	516.28	-	-	-
44	1117.6	164.47	218.90	246.04	273.13	300.18	327.17	346.03	354.11	381.01	407.85	434.65	461.45	488.09	514.74	541.34	-	-	-
46	1168.4	171.99	228.92	257.32	285.66	313.96	342.2	361.94	370.40	398.55	426.64	454.69	482.69	510.64	538.54	566.39	-	-	-
48	1219.2	179.51	238.95	268.59	298.19	327.74	357.23	377.85	386.68	416.08	445.43	474.74	503.99	533.19	562.34	591.45	-	-	-
50	1270	187.02	248.97	279.87	310.72	341.52	372.27	393.76	402.97	433.62	464.22	494.79	525.28	555.74	586.14	616.50	-	-	-
52	1320.8	194.54	258.99	291.14	323.24	355.30	387.30	409.67	419.25	451.16	483.02	514.82	546.58	578.28	609.95	641.55	-	-	-
54	1371.6	202.05	268.01	302.42	335.77	369.08	402.33	425.58	435.54	468.70	501.81	534.87	567.88	600.84	633.75	666.61	-	-	-
56	1422.4	209.57	279.03	313.69	348.30	382.86	417.37	441.49	451.83	486.24	520.60	554.91	589.17	623.39	657.55	691.66	-	-	-
58	1473.2	217.09	289.05	324.96	360.83	396.64	432.40	457.40	468.11	503.77	539.39	574.95	610.47	645.93	681.35	716.72	-	-	-
60	1524	224.60	299.08	336.24	373.35	410.42	447.43	489.22	484.40	521.31	558.18	595.00	631.76	668.48	705.15	741.77	-	-	-
62	1574.8	232.12	309.10	347.51	385.88	424.20	462.46	489.22	500.68	538.85	576.97	615.04	653.06	691.03	728.95	766.83	-	-	-
64	1625.6	239.64	319.12	358.79	398.41	437.98	477.50	505.13	516.97	556.39	595.76	635.08	674.36	713.58	752.76	791.88	-	-	-
66	1676.4	-	-	-	-	-	-	492.53	-	533.25	573.93	614.55	655.13	695.65	736.13	776.56	816.94	857.27	897.55
68	1727.2	-	-	-	-	-	-	507.56	-	549.54	591.47	633.34	675.17	716.95	758.68	800.36	841.99	883.57	925.11
70	1778	-	-	-	-	-	-	522.59	-	565.82	609.00	652.13	695.20	738.25	781.23	824.16	867.05	909.88	952.67
72	1828.8	-	-	-	-	-	-	537.63	-	582.11	626.54	670.92	715.26	759.54	803.78	847.96	892.10	936.19	980.23
74	1879.6	-	-	-	-	-	-	552.66	-	598.39	644.08	689.72	735.30	780.84	826.33	871.77	917.15	962.49	1007.79
76	1930.4	-	-	-	-	-	-	567.69	-	614.68	661.62	708.51	755.35	802.14	848.88	895.57	942.21	988.80	1035.35
78	1981.2	-	-	-	-	-	-	582.73	-	630.97	679.16	727.3	775.39	823.43	871.43	919.37	967.26	1015.11	1062.91
80	2032	-	-	-	-	-	-	597.76	-	647.25	696.69	746.09	795.43	844.73	893.97	943.17	992.32	1041.42	1090.47
82	2082.8	-	-	-	-	-	-	612.79	-	663.54	714.23	764.88	815.48	866.02	916.52	966.97	1017.37	1067.72	1118.03
84	2133.6	-	-	-	-	-	-	627.82	-	679.82	731.77	783.67	835.52	887.32	939.07	990.77	1042.43	1094.03	1145.59
86	2184.4	-	-	-	-	-	-	642.86	-	696.11	749.31	802.46	855.56	908.62	961.62	1014.58	1067.48	1120.34	1173.15
88	2235.2	-	-	-	-	-	-	657.89	-	712.39	766.85	821.25	875.61	929.91	984.17	1038.38	1092.54	1146.65	1200.71
90	2286	-	-	-	-	-	-	672.92	-	728.68	784.39	840.04	895.65	951.21	1006.72	1062.18	1117.59	1172.95	1228.27
92	2336.8	-	-	-	-	-	-	687.95	-	744.96	801.92	858.83	915.83	972.51	1029.27	1085.98	1142.65	1199.26	1255.83
94	2387.6	-	-	-	-	-	-	702.99	-	761.25	819.46	877.62	935.74	993.80	1051.82	1109.78	1167.70	1225.57	1283.39
96	2438.4	-	-	-	-	-	-	718.02	-	777.53	837.00	896.42	955.78	1015.10	1074.37	1133.59	1192.75	1251.87	1310.95
98	2489.2	-	-	-	-	-	-	733.05	-	793.82	854.54	915.21	975.83	1036.40	1096.92	1157.39	1217.81	1278.18	1338.51
100	2540	-	-	-	-	-	-	748.09	-	810.11	872.08	934.00	995.87	1057.69	1119.47	1181.19	1242.86	1304.49	1366.07
102	2590.8	-	-	-	-	-	-	763.12	-	826.39	889.61	952.79	1015.91	1078.99	1142.01	1204.99	1267.92	1330.80	1393.63
104	2641.6	-	-	-	-	-	-	778.15	-	842.68	907.15	971.58	1035.96	1100.28	1164.56	1228.79	1292.97	1357.10	1421.19
106	2692.4	-	-	-	-	-	-	793.18	-	858.96	924.69	990.37	1056.00	1121.58	1187.11	1252.59	1318.03	1383.41	1448.75
108	2743.2	-	-	-	-	-	-	808.22	-	875.25	942.23	1009.16	1076.04	1142.88	1209.66	1276.40	1343.08	1409.72	1476.31
110</																			



**Square & Rectangular Pipe**



**Square Pipe**

Our square formed pipes also made by welding using using Electric Resistance Welding quality consistency. The square pipe is used in structural projects, shelves, benches, trailers, ornamental purposes and other general purpose use. It is widely popular in structural project as this form of pipe is more efficient in comparison with round steel pipes, as it is easily welded than the angular round pipe.

**Rectangular Pipe**

Shaped to rectangular form, we produced this pipe using Electric Resistance Welding autonomous machine. Using this machine we are able to make a consistent welding all along the pipe ensuring the quality of usage for our product.

This hollow pipe are very popular in the industrial production, as it is turned into mass produced products such as supermarket racks, container fabrication, auto fabrication, motor cycles, furniture. It is also used in industrial applications such as scaffolding, water systems, gas pipelines, liquid pipelines, equipment for oil refineries, and structural steel.

The hollow sections of the Rectangular Pipe are used as structural parts for residential, commercial, industrial estates, heavy equipment, and various other useful uses for your construction.

**Standard Dimensional Tolerances :**

JIS G 3466  
SNI 07 – 0068 – 2007 : PKP 30

**Standard Material :**

JIS G 3131 SPHC,  
SAE 1006 / SAE 1008

**Available Size:**

15mm X 30mm up to 50mm X 100 mm

**Annual Capacity:**

36.000 MT/Year

**SNI 07 - 0068 - 2007 PKP 30**

**Rectangular Tube Pipe**

Size (mm)	Thickness (mm)
75 x 45	2.30
	3.20
100 x 50	2.30
	3.20

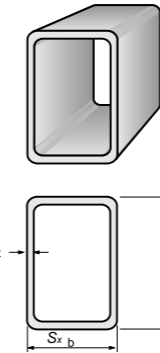

**Square Tube Pipe**

Size (mm)	Thickness (mm)
40 x 40	1.85
	2.30
50 x 50	2.75
	3.20
60 x 40	2.30
	3.20
75 x 75	2.30
	3.20
100 x 100	3.20
	4.00
	4.50

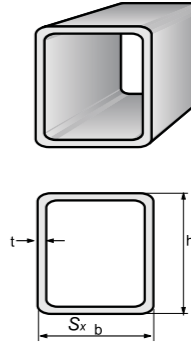

Chemical Composition	
• Phosphor (P)	: 0.05 % max
• Sulphur (S)	: 0.05 % max
Mechanical Properties	
• Tensile Strength	: 294 N/mm <sup>2</sup> min
• Elongation	: 21% min
Tolerance	
• Thickness < 3 mm	: ± 0.3 mm
• 3 mm s/d 12 mm	: ± 10 %
• Length	: ± 2 %
• Side Length < 100 mm	: ± 1.5 mm
• ≥ 100 mm	: ± 10 %
• Corner between two side	: ± 1.5°
• Standard length of pipe	: 6000 mm

NOTE : Non standard sizes are available upon request and subject to minimum quantity.

**SNI 07 - 0068 - 2007 PKP 30**

**Rectangular Tube Pipe**

Size (mm)	Thickness (mm)
75 x 45	2.30
	3.20
100 x 50	2.30
	3.20

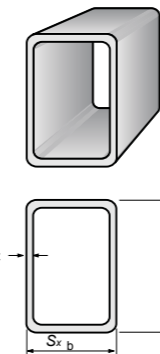

**Square Tube Pipe**

Size (mm)	Thickness (mm)
40 x 40	1.85
	2.30
50 x 50	2.75
	3.20
60 x 40	2.30
	3.20
75 x 75	2.30
	3.20
100 x 100	3.20
	4.00
	4.50

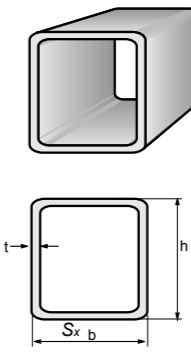

Chemical Composition	
• Phosphor (P)	: 0.05 % max
• Sulphur (S)	: 0.05 % max
Mechanical Properties	
• Tensile Strength	: 294 N/mm <sup>2</sup> min
• Elongation	: 21% min
Tolerance	
• Thickness < 3 mm	: ± 0.3 mm
• 3 mm s/d 12 mm	: ± 10 %
• Length	: ± 2 %
• Side Length < 100 mm	: ± 1.5 mm
• ≥ 100 mm	: ± 10 %
• Corner between two side	: ± 1.5°
• Standard length of pipe	: 6000 mm

NOTE : Non standard sizes are available upon request and subject to minimum quantity.





According to JIS G 3192

Welded Beam Standard Specification

Standard Sectional Dimension				Section Area A	Unit Weight	Unit Weight	Informative Reference					
H x B	t1	t2	r				Geometrical Moment of Inertia		Radius of Gyration of Area		Modulus of Section	
mm	mm	mm	mm				Ix	Iy	ix	iy	Zx	Zy
				mm <sup>2</sup>	kg/m	kg/12m	cm <sup>4</sup>	cm <sup>4</sup>	cm	cm	cm <sup>3</sup>	cm <sup>3</sup>
700 x 300	13	24	28	235.5	181.00	2171	201,000	10,800	29.30	6.78	5,760.00	722.00
800 x 300	14	26	28	267.4	207.00	2474	292,000	11,700	33.00	6.62	7,290.00	782.00
900 x 300	16	28	28	309.8	240.00	2878	411,000	12,600	36.00	6.39	9,140.00	843.00

NOTE: Non standard sizes are available upon request and subject to minimum quantity.

Structural steel, welded I-Sections to AS/NZS 3679.2

Structural Section	Range	AS/NZS 3679.2					AS/NZS 3679.2							
		300	300L15	400	400L15	350	350L15	1	2	3	4	5	6	
		kg/m	Depth of section (d) mm	Flange Width (bf) mm	Flange Thickness (tf) mm	Web Thickness (tw) mm	Depth between flanges (d1) mm	Designation	Depth of section (d) mm	Flange Width (bf) mm	Flange Thickness (tf) mm	Web Thickness (tw) mm	Depth between flanges (d1) mm	
Beams	700WB to 1200WB with web thicknesses 10 to 16mm	✓	✓	✓	✓	✓	✓	1200 WB	455	1 200	500	40.0	16.0	1 120
		✓	✓	✓	✓	✓	✓	423	1 192	500	36.0	16.0	1 120	
		✓	✓	✓	✓	✓	✓	392	1 184	500	32.0	16.0	1 120	
		✓	✓	✓	✓	✓	✓	342	1 184	400	32.0	16.0	1 120	
		✓	✓	✓	✓	✓	✓	317	1 176	400	28.0	16.0	1 120	
		✓	✓	✓	✓	✓	✓	278	1 170	350	25.0	16.0	1 120	
Columns	350WC to 500WC with web thickness 16 to 40mm	✓	✓	✓	✓	✓	✓	249	1 170	275	25.0	16.0	1 120	
		✓	✓	✓	✓	✓	✓	1000 WB	322	1 024	400	32.0	16.0	960
		✓	✓	✓	✓	✓	✓	296	1 016	400	28.0	16.0	960	
		✓	✓	✓	✓	✓	✓	258	1 010	350	25.0	16.0	960	
		✓	✓	✓	✓	✓	✓	215	1 000	300	20.0	16.0	960	
		✓	✓	✓	✓	✓	✓	900 WB	282	924	400	32.0	12.0	860
Beams	700WB to 1200WB with web thicknesses 10 to 16mm	✓	✓	✓	✓	✓	✓	257	916	400	28.0	12.0	860	
		✓	✓	✓	✓	✓	✓	218	910	350	25.0	12.0	860	
		✓	✓	✓	✓	✓	✓	175	900	300	20.0	12.0	860	
		✓	✓	✓	✓	✓	✓	800 WB	192	816	300	28.0	10.0	760
		✓	✓	✓	✓	✓	✓	168	810	275	25.0	10.0	760	
		✓	✓	✓	✓	✓	✓	146	800	275	20.0	10.0	760	
		✓	✓	✓	✓	✓	✓	122	792	250	16.0	10.0	760	
		✓	✓	✓	✓	✓	✓	700 WB	172	716	275	28.0	10.0	660
		✓	✓	✓	✓	✓	✓	150	710	250	25.0	10.0	660	
		✓	✓	✓	✓	✓	✓	130	700	250	20.0	10.0	660	
		✓	✓	✓	✓	✓	✓	115	692	250	16.0	10.0	660	

Welded Beam

Functioned similar to the mass produced H and I beam, the welded beams are made by joining together different plates to form a single beam.

Welded beam serves as the alternatives for construction projects that require beams that are not able to be produced in hot rolled form. Our welded beam products are machine welded and are closely supervised by our qualified technician and engineers to ensure the quality of the welding and the final products.

At GRP, we produce our welded beam in compliance with the JIS G 3192 standard sizes and dimensions. We also provide the services to tailor-made the beam sizes and dimension to suit the unique and challenging construction project as required by our customers.

**Standard & Specification:**  
Supply various specification / international standard like JIS , ASTM , EN , BS , AS , ABS, AS/NZS 3679.2 etc.

**Annual Capacity:**  
60.000 MT/Year

**Available Size:**  
As per customer Requirement  
Flange Width Range: 200 - 1,000 mm  
Web Height Range: 200 - 3,000 mm  
Thickness Flange Range: 8 - 100 mm  
Maximum Length: 25,000 mm





With our ability to process materials that are assisted by the latest technology machines and qualified employees, proving that we can do all your requests.

**Plate Services Center**

**Forming Services Center**

**Coil Services Center**



# Service Center

With facilities spanning over 51.428 sqm, the Plate Service Center (PSC) brings to you the highest quality of service in steel manufacturing and fabrication with the an advanced and precise computerized machines such as CNC sawing machines, CNC drilling, cutting, punching, bending machines, machines for galvanizing & shotblasting etc.

Together with Gunung Raja Paksi's mainstream products and experienced engineers of EFC, our customers are able to buy cut-to-length / cut-to-shape or custom steel fabrication to their requirement and international quality standards.

**Products Serviced:**

King Cross,  
Queen Cross,  
Welded Beam,  
Box Beam

**Service Provided:**

**Angle Line :**  
Cutting, Punching,  
Stamping Angle Line

**Special Operations :** Bending,  
Chamfering, Nothing

**Beam Line :** Bending, Cutting  
(90o&45o), Drilling Copying  
(Honey Comb) Painting  
Shot Blasting

**Welded Beam Line :** Build Up  
Beam, Tackling, Welding

**Straightening Plate Service Center (PSC)**

**Forming Service Center (FSC)**

**Coil Service Center (CSC).**



Coil Services Center



Forming Services Center



Plate Stockle Mill - UT Test Machine

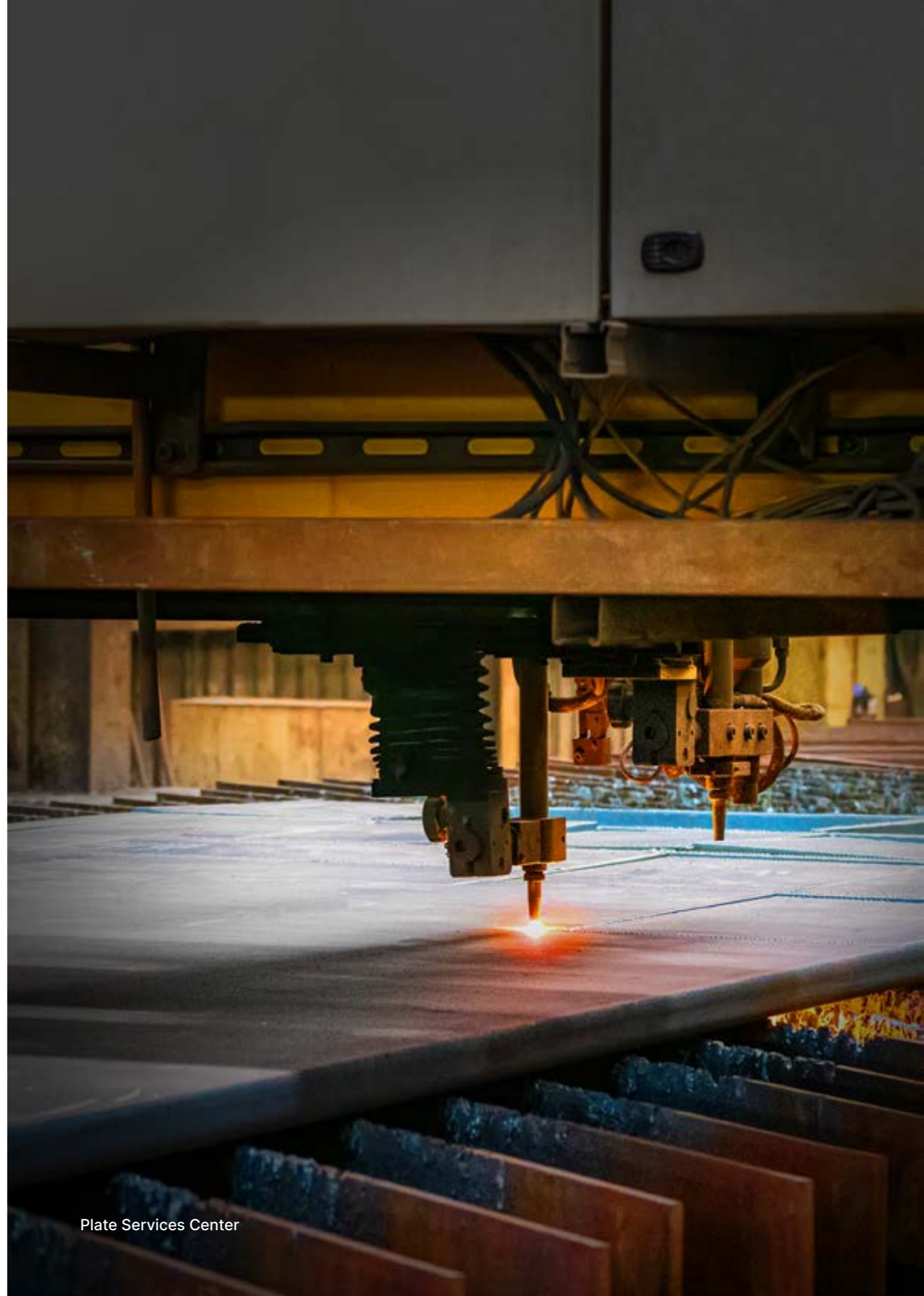

Plate Services Center



# Steel Applications



**Industrial Buildings:**

- Air Pollution Control
- Equipment
- Cement Plants
- Chemical & Petrochemical Plants
- Factory
- Iron & Steel Mills & Wood Process
- Warehouse
- Workshop

**Towers:**

- Pole Tower
- Monumental Tower
- Billboard
- Monitoring Tower
- Wtertank Tower

**High Rise Buildings:**

- Apartment
- Hotel
- Office Building
- Landmark
- Gas Processing & Distribution
- Terminal & Cargo Handling System

**Bridges:**

- Girdes Bridging
- Truss Bridging
- Cantilever Bridging
- Arch Bridging
- Suspension Bridging
- Cable-stayed Bridging
- Railway Bridging

**Low Rise Buildings:**

- Housing / Residence
- Hospital
- Office Building
- Airport / Hangar
- School

**Commercial Buildings:**

- Show Room
- Supermarket & Hypermarket

A close-up photograph of a person's hand holding a black and gold pen, writing on a document. The person is wearing a light blue long-sleeved shirt. The background is a solid red color. The image is split diagonally from the top right to the bottom left.

GRP is very concerned about the quality of products and management system. This is evident from the many international certifications obtained such as **ISO 9001, ISO 14001, OHSAS 18001, SNI, ABS, JIS Marking, Lloyd Register (LR), BKI, Germanischer Lloyd (GL), Det Norske Veritas (DNV), Nippon Kaiji Kyokai (NK),** and others.

# Certifications





# Thank you for choosing GRP as a solutions to your steel requirements.

We are confident that our products and services excellence shall satisfy your requirements and our partnership will continue to grow.



Website GRP



Member of





SHAPING TOMORROW

**PT Gunung Raja Paksi Tbk**

Jl. Perjuangan No.15  
Sukadanau, Cikarang Barat  
Bekasi 17530  
West Java, Indonesia

Phone: +62 21 890-0111

Fax: +62 21 890-0555

Email: [gsg@gunungsteel.com](mailto:gsg@gunungsteel.com)

